

ME3592 METROLOGY AND MEASUREMENTS

UNIT I BASICS OF METROLOGY

Introduction to Metrology – Need – Elements – Work piece, Instruments – Persons – Environment – their effect on Precision and Accuracy – Errors – Errors in Measurements – Types – Control – Types of standards.

UNIT II LINEAR AND ANGULAR MEASUREMENTS

Linear Measuring Instruments – Evolution – Types – Classification – Limit gauges – gauge design – terminology – procedure – concepts of interchange ability and selective assembly – Angular measuring instruments – Types – Bevel protractor clinometers angle gauges, spirit levels sine bar – Angle alignment telescope – Autocollimator – Applications.

UNIT III ADVANCES IN METROLOGY

Basic concept of lasers Advantages of lasers – laser Interferometers – types – DC and AC Lasers interferometer – Applications – Straightness – Alignment. Basic concept of CMM – Types of CMM – Constructional features – Probes – Accessories – Software – Applications – Basic concepts of Machine Vision System – Element – Applications.

UNIT IV FORM MEASUREMENT

Principles and Methods of straightness – Flatness measurement – Thread measurement, gear measurement, surface finish measurement, Roundness measurement – Applications.

UNIT V MEASUREMENT OF POWER, FLOW AND TEMPERATURE

Force, torque, power - mechanical , Pneumatic, Hydraulic and Electrical type. Flow measurement: Venturimeter, Orifice meter, rotameter, pitot tube – Temperature: bimetallic strip, thermocouples, electrical resistance thermometer– Reliability and Calibration – Readability and Reliability.

TOTAL : 45 PERIODS

TEXT BOOKS:

1. Gupta. I.C., “Engineering Metrology”, Dhanpatrai Publications, 2005.
2. Jain R.K. “Engineering Metrology”, Khanna Publishers, 2009.

REFERENCES:

1. Alan S. Morris, “The essence of Measurement”, Prentice Hall of India 1996.
2. Beckwith, Marangoni, Lienhard, “Mechanical Measurements”, Pearson Education , 2014.
3. Charles Reginald Shotbolt, “Metrology for Engineers”, 5th edition, Cengage Learning EMEA, 1990.
4. Donald Peckman, “Industrial Instrumentation”, Wiley Eastern, 2004.
5. Raghavendra ,Krishnamurthy “Engineering Metrology & Measurements”, Oxford Univ. Press, 2013.

DEPARTMENT OF MECHANICAL ENGINEERING

Subject Name : METROLOGY AND MEASUREMENTS **Code** : ME3592
Year : III **Semester** : V
Degree & Branch : B.E. – MECHANICAL

UNIT -1 BASICS OF METROLOGY

PART-A

1. What is Range of measurement? (NOV/DEC2015)

The physical variables that are measured between two values. One is the higher calibration value H, and the other is Lower value L, The difference between H, and L, is called range.

2. What is Legal metrology? (MAY/JUNE2014)

Legal metrology is part of Metrology and it is directed by a national organization which is called national service of legal Metrology.

3. Differentiate between sensitivity and range with suitable example? (MAY/JUNE2014)

Example: A Instrument have a scale reading of 0.01mm to 100mm. Here, the sensitivity of the instrument is 0.01mm i.e. the minimum value in the scale by which the instrument can read. The range is 0.01 to 100mm i.e. the minimum to maximum value by which the instrument can read.

4. Define system error and correction Error? (NOV/DEC2011)

The deviation between the results of measured value to the actual value. Correction: The numerical value which should be added to the measured value to get the correct result.

5. Define: Readability? (NOV/DEC2012)

It is a term frequently used for analog type instruments. This characteristic depends on both the instrument and observer.

6. Define Calibration? (NOV/DEC2014)

Calibration is the process of determining and adjusting an instruments accuracy to make sure its accuracy is within the manufacturer's specifications

7. What is Hysteresis? (NOV/DEC2004)

All the energy put into the stressed component when loaded is not recovered upon unloading. So, the output of measurement partially depends on input called hysteresis.

8. What is measurement? Give it types? (MAY/JUNE2008)

It is the process of comparing the input signal with predefined standard and it gives out the result. It is a word used to describe about physical quantities such as length, weight, temperature, pressure, force etc

Types

1. Primary measurements

2. Secondary measurements.

3. Tertiary measurements

9. Define the term reliability? (NOV/DEC2008)

Reliability is the ability of a person or system to perform and maintain its functions in routine circumstances.

10. What is static response? (NOV/DEC2012)

Measured variables are many times steady, that is, they do not vary with time. That is they are static in nature.

11. Differentiate between precision and accuracy? (NOV/DEC2014)

Accuracy - The maximum amount by which the result differs from true value. Precision - Degree of repetitiveness. If an instrument is not precise it will give different results for the same dimension for the repeated readings.

12. Brief on sensitivity in measurement. (NOV/DEC2016)

Sensitivity is an absolute quantity, the smallest absolute amount of change that can be detected by a measurement.

13. Differentiate between accuracy and precision. (NOV/DEC2016)

Accuracy can be defined as the amount of uncertainty in a measurement with respect to an absolute standard.

Precision describes the reproducibility of the measurement. For example, measure a steady state signal many times.

14. Define Traceability. (April/May 2017)

The term "measurement traceability" is used to refer to an unbroken chain of comparisons relating an instrument's measurements to a known standard. Calibration to a traceable standard can be used to determine an instrument's bias, precision, and accuracy.

15. What is difference between gauging and measurements? (April/May 2017)

Gauging is the process of determining the exact dimensions, capacity, quantity, or force of measure.

A **measurement** is a method of determining quantity, capacity, or dimension. Several systems of measurement exist, each one comprising units whose amounts have been arbitrarily set and agreed upon by specific groups.

Part-B

1. Define standards. Discuss different type of standards in detail? (APR/MAY 2017)

Standards

The term standard is used to denote universally accepted specifications for devices. Components are processes which ensure conformity and interchangeability throughout a particular industry. A standard provides a reference for assigning a numerical value to a measured quantity.

Each basic measurable quantity has associated with it an ultimate standard. Working standards, those used in conjunction with the various measurement making instruments.

The national institute of standards and technology (NIST) formerly called National Bureau of Standards (NBS), it was established by an act of congress in 1901, and the need for such body had been noted by the founders of the constitution. In order to maintain accuracy, standards in a vast industrial complex must be trace able to a single source, which may be national standards.

The following is the generalization of echelons of standards in the national measurement system.

1. Calibration standards
2. Metrology standards
3. National standards

Calibration standards: Working standards of industrial or government alllaboratories.

Metrology standards: Reference standards of industrial or Government alllaboratories.

National standards: It includes proto type and natural phenomenon of SI (Systems International), the world wide system of weight and measures standards. Application of precise measurement has increased so much, that a single national laboratory to perform directly all the calibrations and standardization required by large country with high technical development. It has led to the establishment of a considerable number of standardizing laboratories in industry and in various other areas. A standard provides a reference or datum for assigning a numerical value to a measured quantity.

Classification of Standards

To maintain accuracy and interchangeability it is necessary that Standards to be trace able to a single source, usually the National Standards of the country, which are further linked to International Standards. The accuracy of National Standards is transferred to working standards through a chain of intermediate standards in a manner given below.

- National Standards
- National Reference Standards
- Working Standards
- Plant Laboratory Reference Standards
- Plant Laboratory Working Standards
- Shop Floor Standards

2. Describe the different types of error in measurement and their causes and control methods in detail? (MAY/JUNE2014) (NOV/DEC2014) (NOV/DEC2016)(APR/MAY 2017)

ERRORS IN MEASUREMENTS

It is never possible to measure the true value of a dimension there is always some error. The

error in measurement is the difference between the measured value and the true value of the measured dimension.

$$\text{Error in measurement} = \text{Measured value} - \text{True value}$$

Absolute Error

True absolute error:

It is the algebraic difference between the result of measurement and the conventional true value of the quantity measured.

Apparent absolute error:

If the series of measurement are made and then the algebraic difference between one of the results of measurement and the arithmetical mean is known as apparent absolute error.

Relative Error:

It is the quotient of the absolute error and the value of comparison used or calculation of that absolute error. This value of comparison may be the true value, the conventional true value or the arithmetic mean for series of measurement.

Types of Errors

Systematic Error

These errors include calibration errors, error due to variation in the atmospheric condition variation in contact pressure etc. If properly analyzed, these errors can be determined and reduced or even eliminated hence it also called controllable errors. All other systematic errors can be controlled in a magnitude and sense except personal error.

These errors result from irregular procedure that is consistent in action. These errors are repetitive in nature and are of constant and similar form.

Random Error

These errors are caused due to variation in position of setting standard and work –piece errors. Due to displacement of level joints of instruments, due to back lash and friction, these errors are induced. Specific cause, magnitude and sense of these errors cannot be determined from the knowledge of measuring system or condition of measurement. These errors are non-consistent and hence the name random errors.

Environmental Error

These errors are caused due to effect of surrounding temperature, pressure and humidity on the measuring instrument. External factors like nuclear radiation, vibrations and magnetic field also leads to error. Temperature plays an important role where high precision is required .e.g. while using slip gauges, due to handling the slip gauges may acquire human body temperature, where as the work is at 20°C. A 300mm length will go in error by 5microns which is quite a considerable error. To avoid errors of this kind, all metrology laboratories and standard rooms worldwide are maintained at 20°C.

3. Distinguish between precision and accuracy with illustration? (MAY / JUNE 2012) (NOV/DEC 2010)

Precision

The terms precision and accuracy are used in connection with the performance of the instrument. Precision is the repeatability of the measuring process. It refers to the group of measurements for the same characteristics take number identical conditions. It indicates to what extent the identically performed measurements agree with each other. If the instrument is not precise it will give different (widely varying) results for the same dimension when measured again and again. These to observations will scatter about the mean. The scatter of these measurements is designated as σ , the standard deviation. It is used as an index of precision. The less the scattering more precise is the instrument. Thus, lower, the value of σ , the more precise is the instrument.

Accuracy

Accuracy is the degree to which the measured value of the quality characteristic agrees with the true value. The difference between the true value and the measured value is known as error of measurement. It is practically difficult to measure exactly the true value and therefore a set of observations is made whose mean value is taken as the true value of the quality measured.

Distinction between Precision and Accuracy

Accuracy is very often confused with precision though much different. The distinction between the precision and accuracy will become clear by the following example. Several measurements are made on a component by different types of instruments (A, B and C respectively) and the results are plotted. In any set of measurements, the individual measurements are scattered about the mean, and the precision signifies how well the various measurements performed by same instrument on the same quality characteristic agree with each other. The difference between the mean of set of readings on the same quality characteristic and the true value is called as error. Less the error more accurate is the instrument. Figure shows that the instrument A is precise since the results of number of measurements are close to the average value. However, there is a large difference (error) between the true value and the average value hence it is not accurate. The readings taken by the instruments are scattered much from the average value and hence it is not precise but accurate as there is a small difference between the average value and true value.

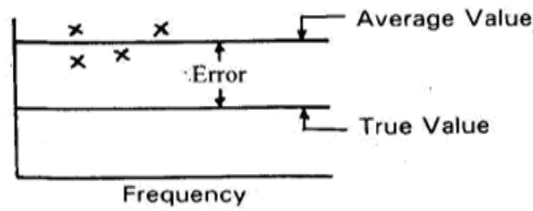

(a) Precise but not accurate

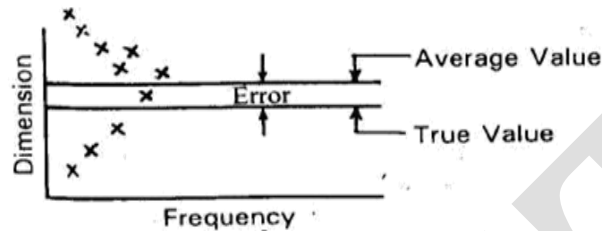

(b) Accurate but not precise

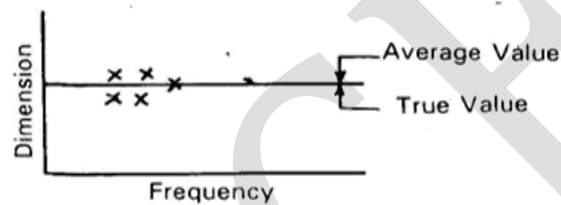

(c) Accurate & precise

4. List the various measurement methods and explain? (NOV/DEC2008)METHODS

OF MEASUREMENTS

These are the methods of comparison used in measurement process. In precision measurement various methods of measurement are adopted depending upon the accuracy required and the amount of permissible error.

The methods of measurement can be classified as:

1. Direct method
2. Indirect method
3. Absolute or Fundamental method
4. Comparative method
5. Transposition method
6. Coincidence method
7. Deflection method
8. Complementary method
9. Contact method
10. Contactless method

Direct method of measurement:

This is a simple method of measurement, in which the value of the quantity to be measured is obtained directly without any calculations. For example, measurements by using scales, vernier calipers, micrometers, bevel protector etc. This method is most widely used in production. This method is not very accurate because it depends on human in sensitiveness in making judgment.

Indirect method of measurement:

In indirect method the value of quantity to be measured is obtained by measuring other quantities which are functionally related to the required value.

E.g. Angle measurement by sine bar, measurement of screw pitch diameter by three wire method etc.

Absolute or Fundamental method:

It is based on the measurement of the base quantities used to define the quantity. For example, measuring a quantity directly in accordance with the definition of that quantity, or measuring a quantity indirectly by direct measurement of the quantities linked with the definition of the quantity to be measured.

Comparative method:

In this method the value of the quantity to be measured is compared with known value of the same quantity or other quantity practically related to it. So, in this method only the deviations from a master gauge are determined, e.g., dial indicators, or other comparators.

Transposition method:

It is a method of measurement by direct comparison in which the value of the quantity measured is first balanced by an initial known value A of the same quantity, and then the value of the quantity measured is put in place of this known value and is balanced again by another known value B. If the position of the element indicating equilibrium is the same in both cases, the value of the quantity to be measured is AB . For example, determination of a mass by means of a balance and known weights, using the Gauss double weighing.

Coincidence method:

It is a differential method of measurement in which a very small difference between the value of the quantity to be measured and the reference is determined by the observation of the coincidence of certain lines or signals. For example, measurement by vernier caliper micrometer.

Deflection method:

In this method the value of the quantity to be measured is directly indicated by a deflection

of a pointer on a calibrated scale.

Complementary method:

In this method the value of the quantity to be measured is combined with a known value of the same quantity. The combination is so adjusted that the sum of these two values is equal to a predetermined comparison value. For example, determination of the volume of a solid by liquid displacement.

Method of measurement by substitution:

It is a method of direct comparison in which the value of a quantity to be measured is replaced by a known value of the same quantity, so selected that the effects produced in the indicating device by these two values are the same.

Method of null measurement:

It is a method of differential measurement. In this method the difference between the value of the quantity to be measured and the known value of the same quantity with which it is compared is brought to zero.

5. Draw the block diagram of generalized measurement system and explain different stages with examples. (NOV/DEC2015)

A measuring system exists to provide information about the physical value of some variable being measured. In simple cases, the system can consist of only a single unit that gives an output reading or signal according to the magnitude of the unknown variable applied to it. However, in more complex measurement situations, a measuring system consists of several separate elements as shown in Figure

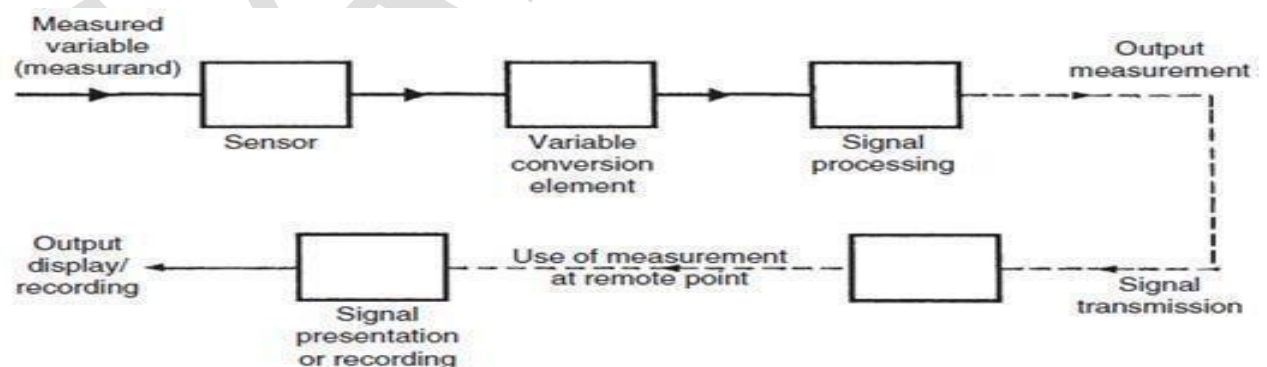

The various elements of measurement system are,

- a. Primary sensing Element
- b. Variable conversion element.
- c. Variable manipulation element
- d. Data transmission element.
- e. Data processing Element

f. Data presentation element.

a. Primary sensing Element

It is the first element which receives energy from the measured medium and it produces an output corresponding to the measurand. This output is then converted into an analogous electrical signal by a transducer.

b. Variable conversion element.

It converts the output electrical signal of the primary sensing element into a more suitable form signal without changing the information contained in the input signal. In some instruments, there is no need of using a variable conversion element while some other instruments require the variable conversion element.

c. Variable manipulation element

This element is used to manipulate the signal presented to it and preserving the original nature of the signal. In other words, it amplifies the input signal to the required magnification. For example an electronic voltage amplifier receives a small voltage as input and it produces greater magnitude of voltage as output. A variable manipulation element does not necessarily follow a variable conversion element and it may precede it.

d. Data transmission element.

It transmits the data from one element to the other. It may be as shaft and gear assembly system or as complicated as a telemetry system which is used to transmit the signal from one place to another.

e. Data processing Element

It is an element which is used to modify the data before displayed or finally recorded. It may be used for the following purposes.

To convert the data into useful form To separate the signal hidden in noise

It may provide corrections to the measured physical variables to compensate for zero offset, temperature error, scaling etc

f. Data presentation element.

These are the elements that they finally communicate the information of measured variables to a human observer for monitoring, controlling or analyzing purposes. The value of measured variables may be indicated by an analog indicator, digital indicator, or by a recorder

Part C

1. Distinguish between and give appropriate examples in each case

i) Repeatability and Reproducibility (NOV/DEC2014)

ii) Systematic and Random errors (NOV/DEC2006)

iii) Static and Dynamic response (NOV/DEC2006)

1. Repeatability

Repeatability may be defined as the closeness of agreement among the number of consecutive measurement of the output for the same value of input under the same operating conditions. It may be specified in terms of units for a given period of time.

2) Reproducibility

Reproducibility may be defined as the closeness of agreement among the repeated measurements of the output for the same value of input under the same operating conditions over a period of time. Perfect reproducibility means that the instrument calibration does not gradually shift over a long period of time.

3) Systematic error:

It is the error which during several measurements, made under the same conditions, of the same value of a certain quantity, remains constant in absolute value and sign or varies in a predictable way in accordance with a specified law when the conditions change. The causes of these errors may be known or unknown. The errors may be constant or variable. Systematic errors are regularly repetitive in nature.

4) Random error:

This error varies in an unpredictable manner in absolute value & in sign when a large number of measurements of the same value of a quantity are made under practically

5. Static response:

The static characteristics of an instrument are considered for instruments which are used to measure an unvarying process conditions.

6. Dynamic response:

The behaviors of an instrument under such time varying input – output conditions called Dynamic response of an instrument. The instrument analysis of such dynamic response is called dynamic analysis of the measurement system.

2. With suitable example explain the elements of generalized measurement system.

Components of Generalized Measurement System:

A generalized measurement system consists of the following components: Primary Sensing Element Variable Conversion Element Variable Manipulation Element Data Processing Element Data Transmission System Data Presentation Element

In addition to the above components, a measurement system may also have a data storage element to store measured data for future use. As the above six components are the most common ones used in many measurement systems, they are discussed in detail below:

1. Primary Sensing Element:

The primary sensing element receives signal of the physical quantity to be measured as input. It converts the signal to a suitable form (electrical, mechanical or other form), so that it becomes easier for other elements of the measurement system, to either convert or manipulate it.

2. Variable Conversion Element:

Variable conversion element converts the output of the primary sensing element to a more suitable form. It is used only if necessary.

3. Variable Manipulation Element:

Variable manipulation element manipulates and amplifies the output of the variable conversion element. It also removes noise (if present) in the signal.

4. Data Processing Element:

Data processing element is an important element used in many measurement systems. It processes the data signal received from the variable manipulation element and produces suitable output.

Data processing element may also be used to compare the measured value with a standard value to produce required output.

5. Data Transmission System:

Data Transmission System is simply used for transmitting data from one element to another. It acts as a communication link between different elements of the measurement system. Some of the data transmission elements used are cables, wireless antennae, transducers, telemetry systems etc.

6. Data Presentation Element:

It is used to present the measured physical quantity in a human readable form to the observer. It receives processed signal from data processing element and presents the data in a human readable form. LED displays are most commonly used as data presentation elements in many measurement systems.

UNIT-2 LINEAR AND ANGULAR MEASUREMENTS

Part-A

1. List any four angular measuring instruments(APRIL/MAY 2016)

- Sinebar
- Bevel protractor
- Autocollimeter
- Angle dekkor

2. Why are sine bars not used for measuring large angles (APR/MAY 2015)

- The sine bar is physically clumsy to hold in position.
- The body of the sine bar obstructs the gauge block stack even if relieved
- Slight errors of the sine bar cause large angular errors

3. State the principle of interferometry. NOV/DEC 2015

Interferometry makes the use of the principle of superposition to combine separate wave together in a way that will cause the result of the combination to have some meaningful property that is diagnostic of the original state of the waves.

4. Classify the comparator according to the principles used for obtaining magnification.

The common types are: (i) Mechanical comparators. (ii) Electrical comparators. (iii) Optical comparators. (iv) Pneumatic comparators. 34. How the mechanical comparator works? The method of magnifying small movement of the indicator in all mechanical comparators are effected by means of levers, gear trains or a combination of these elements.

5. How the mechanical comparator is used?

State with any one example. Let us assume that the required height of the component is 32.5mm. Initially, this height is built up with slip gauges. The slip gauge blocks are placed under the stem of the dial gauge. The pointer in the dial gauge is adjusted to zero. The slip gauges are removed- Now, the component to be checked is introduced under the stem of the dial gauge. If there is any deviation in the height of the component, it will be indicated by the pointer.

6. State any four advantages of mechanical comparator. MAY/JUN 2013

- i. It is usually robust, compact and easy to handle.
- ii. There is no external supply such as electricity are required.
- iii. It has very simple mechanism and is cheaper when compared to other types.
- iv. It is suitable for ordinary workshop and also easily portable.

7. Mention any two disadvantages of reed type mechanical comparator.

- Accuracy of the comparator mainly depends on the accuracy of the rack and pinion arrangement. Any slackness will reduce accuracy.
- It has more moving parts and hence friction is more and accuracy is less.

8. What are the advantages of electrical and electronic comparator?

MAY/JUNE 2014

- It has less number of moving parts.
- Magnification obtained is very high.
- Two or more magnifications are provided in the same instrument to use various ranges.
- The pointer is made very light so that it is more sensitive to vibration.

9. What are the advantages of pneumatic comparator? (APRIL/MAY 2016)

- The wear of measuring heads is avoided due to absence of direct contact.
- Friction is less due to less number of moving parts.
- Work piece is cleaned by supplying of air during the measurement.
- High magnification is possible.
- There is no interference of measuring head and indicating device because the measuring head is kept away from the indicating device.

11. Why lasers are used in Metrology? (NOV/DEC 2015)

- Intensity of laser can be easily changed.
- It helps for high accurate measurement

12. Write any two precautions to be followed when using gauge block. (NOV/DEC 2015)

- The gauge block surface should be cleaned from dust particles.
- Wringing and slipping process should be done before measurement.

13. State the working principle of Electronic comparator. MAY/JUNE 2014

In an electronic comparator, transducer or the principle of application of frequency modulation or radio oscillation is followed.

14. Write the constructional requirements of the sine bar for accurate measurement NOV/DEC 2014

- The rollers must have equal diameter and equal cylinders
- The rollers should be placed parallel to each other and also to the upper face.
- The accurate center to center of rollers must be known.

15. Write a short notes on Bevel protractor? (Nov Dec 2016)

A bevel protractor is a graduated circular protractor with one pivoted arm used for

measuring or marking off angles

16. Write short notes on Interchangeability? (Nov Dec 2016)

It refers to Interchangeable parts, the ability to select components for assembly at random and fit them together within proper tolerances.

17. Why is rocking procedure followed when measuring with a dial bore gauge? (April May 2017)

The rocking will first align the gauge with the bore axis and the act of moving the handle to the other side of the bore will bring it to the exact borediameter.

18. Name any four instruments used measuring internal diameters in components. (April May 2017)

- Inside Micrometer
- Bore Gauge
- Caliper Type Inside Micrometer
- Vernier Caliber

PART-B

11. Give a brief note on slip gauges and what are the safety precaution to be followed in the use of slip gauge blocks and also explain the type of limit gauge with neat sketches (APRIL /MAY 2015) ?(NOV/DEC2016)

SLIPGAUGES

These may be used as reference standards for transferring the dimension of the unit of length from the primary standard to gauge blocks of lower accuracy and for the verification and graduation of measuring apparatus.

These are high carbon steel hardened, ground and lapped rectangular blocks, having cross sectional area of 30mm, 10mm. Their opposite faces are flat, parallel and are accurately the stated distance apart.

The opposite faces are of such a high degree of surface finish, that when the blocks are pressed together with a slight twist by hand, they will wring together. They will remain firmly attached to each other. They are supplied in sets of 112 pieces down to 32pieces.

Due to properties of slip gauges, they are built up by, wringing into combination which gives size, varying by steps of 0.01 mm and the overall accuracy is of the order of 0.00025mm. Slip gauges with three basic forms are commonly found, these are rectangular, square with center hole, and square without center hole.

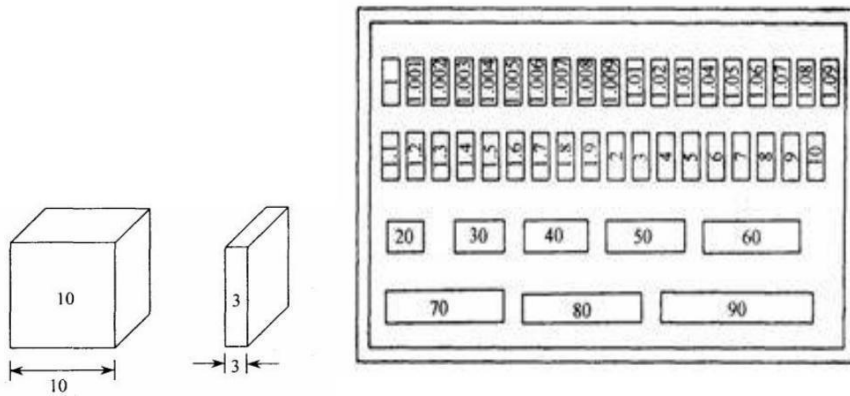

Precautions

- The blocks should be kept in the box and it should not be dropped on the irregular surfaces.
- Surfaces of slip gauges should be cleaned before it is used.
- The slip gauge block should be in particular temperature condition to eliminate the thermal expansion which causes inaccuracy during measurement.
- While using slip gauges for measurement it should be kept on a flat surface to get high accurate readings.

LIMIT GAUGES

- A limit gauge is not a measuring gauge. Just they are used as inspecting gauges.
- The limit gauges are used in inspection by methods of attributes.
- This gives the information about the products which may be either within the prescribed limit or not.
- By using limit gauges report, the control charts of P and C charts are drawn to control invariance of the products.
- This procedure is mostly performed by the quality control department of each and every industry.
- Limit gauges are mainly used for checking for cylindrical holes of identical components with a large number in mass production.

Purpose of using limit gauges

- Components are manufactured as per the specified tolerance limits, upper limit and lower limit. The dimension of each component should be within this upper and lower limit.
- If the dimensions are outside these limits, the components will be rejected.
- It is just enough whether the size of the component is within the prescribed limits or not. For this purpose, we can make use of gauges known as limit gauges.

The common types are as follows:

- 1) Plug gauges.
- 2) Ring gauges.
- 3) Snap gauges.

PLUGGAUGES

- The ends are hardened and accurately finished by grinding. One end is the GO end and the other end is NOGO end.
- Usually, the GO end will be equal to the lower limit size of the hole and the NOGO end will be equal to the upper limit size of the hole.
- If the size of the hole is within the limits, the GO end should go inside the hole and NOGO end should not go.
- If the GO end does not go, the hole is under size and also if NOGO end goes, the hole is over size. Hence, the components are rejected in both the cases

1. Double ended plug gauges

In this type, the GO end and NOGO end are arranged on both the ends of the plug. This type has the advantage of easy handling.

2. Progressive type of plug gauges

In this type both the GO end and NOGO end are arranged in the same side of the plug. We can use the plug gauge ends progressively one after the other while checking the hole. It saves time. Generally, the GO end is made larger than the NOGO end in plug gauges.

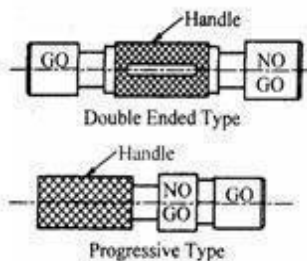

TAPER PLUG GAUGE

Taper plug gauges are used to check tapered holes. It has two check lines. One is a GO line and another is a NOGO line. During the checking of work, NOGO line remains outside the hole and GO line remains inside the hole.

They are various types taper plug gauges are available as shown in fig. Such as

- 1) Taper plug gauge— plain
- 2) Taper plug gauge— tanged.
- 3) Taper ring gauge plain
- 4) Taper ring gauge — tanged

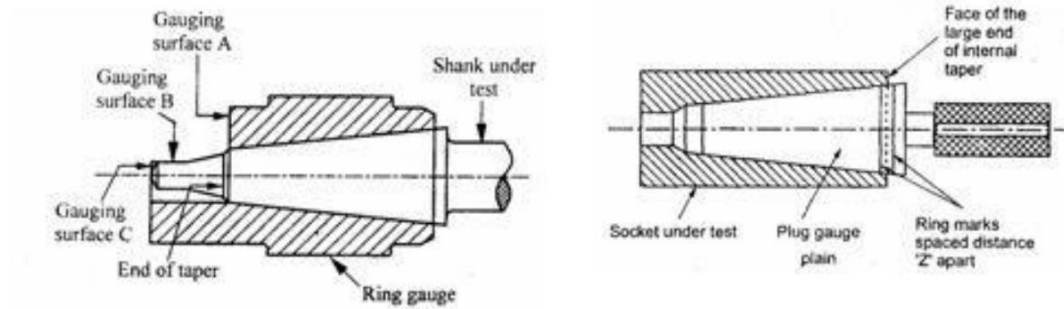

RING GAUGES

- Ring gauges are mainly used for checking the diameter of shafts having a central hole. The hole is accurately finished by grinding and lapping after taking hardening process.
- The periphery of the ring is knurled to give more grips while handling the gauges. We have to make two ring gauges separately to check the shaft such as GO ring gauge and NOGO ring gauge.
- But the hole of GO ring gauge is made to the upper limit size of the shaft and NOGO for the lower limit.
- While checking the shaft, the GO ring gauge will pass through the shaft and NO GO will not pass.
- To identify the NOGO ring gauges easily, are mark or a small groove cut on its periphery.

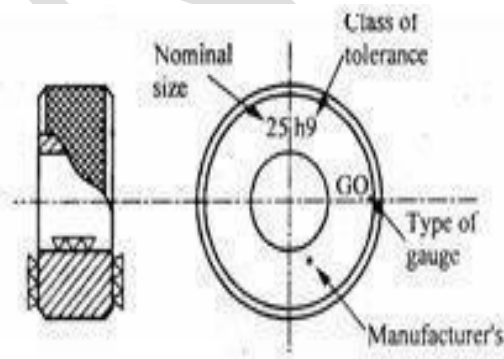

SNAP GAUGE

Snap gauges are used for checking external dimensions. They are also called a snap gauges. The different types of snap gauges are:



Double Ended Snap Gauge

This gauge is having two ends in the form of anvils. Here also, the GO anvil is made to lower limit and NOGO anvil is made to upper limit of the shaft. It is also known as solid snap gauges

Progressive Snap Gauge

This type of snap gauge is also called caliper gauge. It is mainly used for checking large diameters up to 100mm. Both GO and NOGO anvils at the same end.

The GO anvil should be at the front and NOGO anvil at the rear. So, the diameter of the shaft is checked progressively by these two ends. This type of gauge is made of horse shoe shaped frame with I section to reduce the weight of the snap gauges.

Adjustable Snap Gauge

Adjustable snap gauges are used for checking large size shafts made with horse shoe shaped frame of I section. It has one fixed anvil and two small adjustable anvils. The distance between the two anvils is adjusted by adjusting the adjustable anvils by means of set screws. This adjustment can be made with the help of slip gauges for specified limits of size.

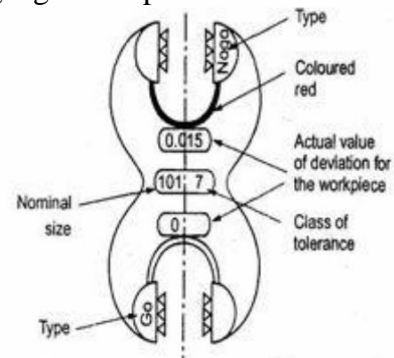
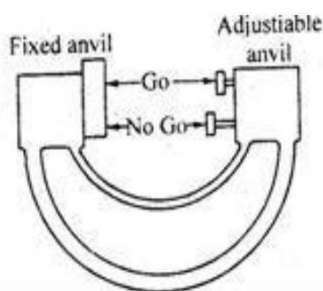

Combined Limit Gauges

A spherical projection is provided with GO and NOGO dimension marked in a single gauge. While using GO gauge the handle is parallel to axes of the hole and normal to axes for NOGO gauge.

Position Gauge

It is designed for checking the position of features in relation to another surface. Other types of gauges are also available such as contour gauges, receiver gauges, profile gauges etc.

12. Explain the construction and working of vernier caliper. Enumerate the different types of vernier caliper with neat sketches also explain the construction and working of micrometers. Enumerate the micrometer with neat sketches. (APRIL/MAY 2015)

VERNIERCALIPERS

The vernier instruments generally used in workshop and engineering metrology have comparatively low accuracy. The line of measurement of such instruments does not coincide with the line of scale. The accuracy therefore depends upon the straightness of the beam and the squareness of the sliding jaw with respect to the beam.

To ensure the squareness, the sliding jaw must be clamped before taking the reading. The zero error must also be taken into consideration. Instruments are now available with a measuring range up to one meter with a scale value of 0.1 or 0.2 mm.

Types of Vernier Calipers

According to Indian Standard IS:3651- 1974, three types of vernier calipers have been specified to make external and internal measurements and are shown in figures respectively. All the three types are made with one scale on the front of the beam for direct reading.

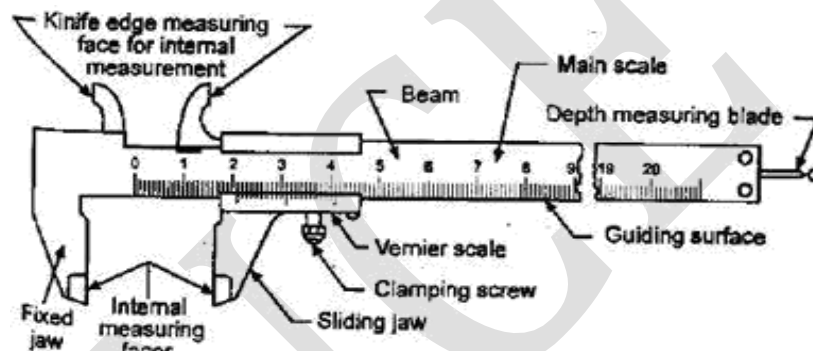

Type A : Vernier has jaws on both sides for external and internal measurements and a blade for depth measurement.

Type B : It is provided with jaws on one side for external and internal measurements.

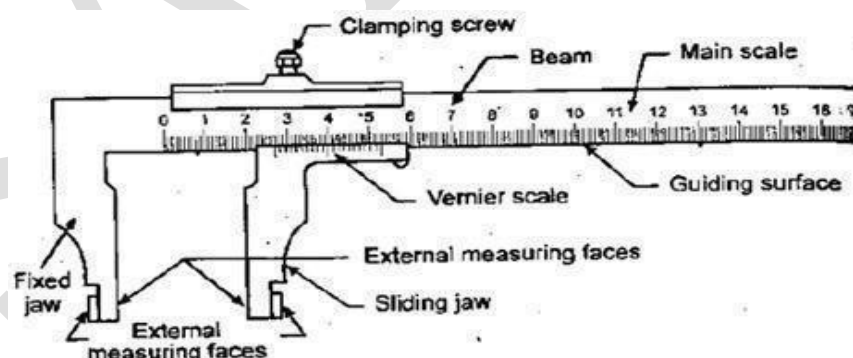

Type C : It has jaws on both sides for making the measurement and for marking operations

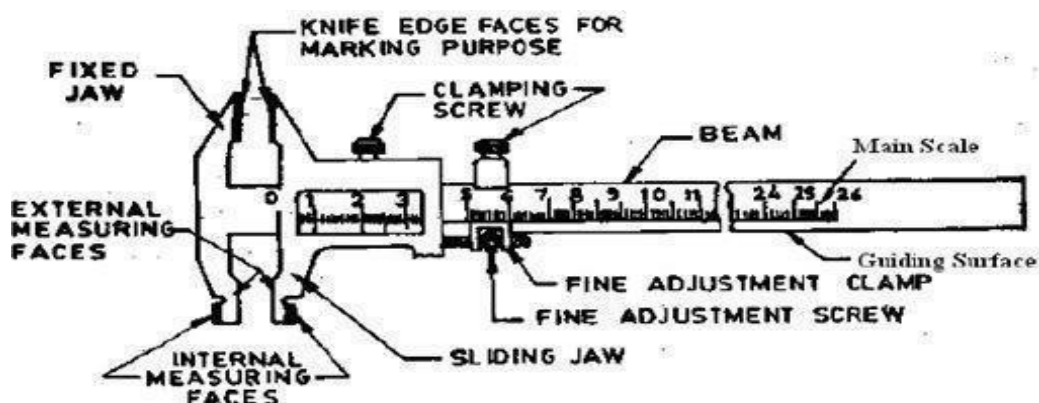

MICROMETERS

There are two types in it.

- Outside micrometer— To measure external dimensions.
- Inside micrometer—To measure internal dimensions

An outside micrometer is shown. It consists of two scales, main scale and thimble scale. While the pitch of barrel screw is 0.5mm the thimble has graduation of 0.01mm. The **least count** of this micrometer is 0.01 mm.

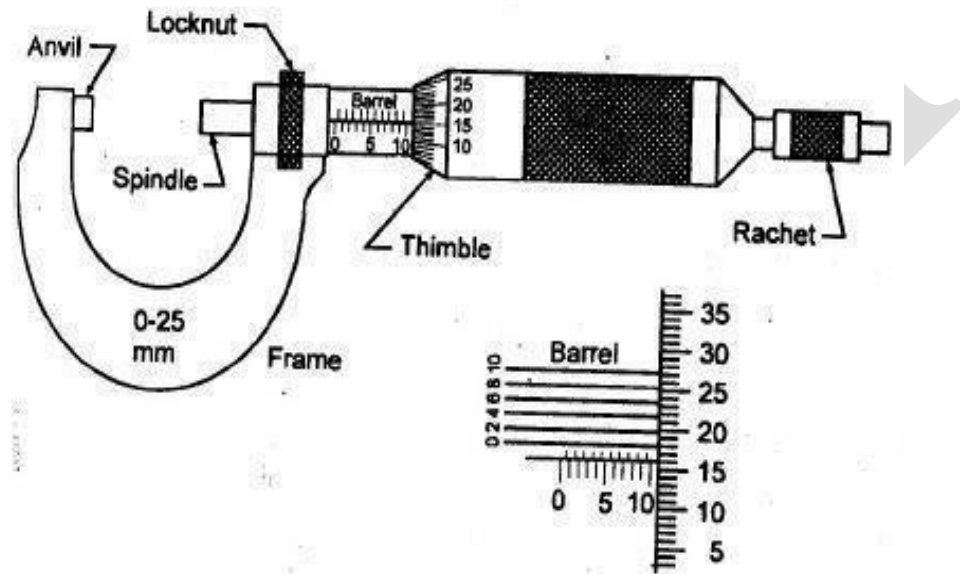

The micrometer requires the use of an accurate screw thread as a means of obtaining a measurement. The screw is attached to a spindle and is turned by movement of a thimble or ratchet at the end. The barrel, which is attached to the frame, acts as a nut to engage the screw threads, which are accurately made with a pitch of 0.05mm. Each revolution of the thimble advances the screw 0.05mm. On the barrel a datum line is graduated with two sets of division marks.

13.Explain the working principle of mechanical comparator ,optical comparator and Pneumatic comparator with neat sketches (MAY/JUNE 2014)

COMPARATORS

Comparators are one form of linear measurement device which is quick and more convenient for checking large number of identical dimensions.Comparators normally will not show the actual dimensions of the work piece. They will be shown only the deviation in size.

During the measurement a comparator is able to give the deviation of the dimension from the set dimension. This cannot be used as an absolute measuring device but can only compare two

dimensions. Comparators are designed in several types to meet various conditions.

Comparators of every type incorporate some kind of magnifying device. The magnifying device magnifies how much dimension deviates, plus or minus, from the standard size.

The comparators are classified according to the principles used for obtaining magnification. The common types are:

- 1) Mechanical comparators
- 2) Electrical comparators
- 3) Optical comparators
- 4) Pneumatic comparators

MECHANICAL COMPARATORS

Mechanical comparator employs mechanical means for magnifying small deviations. The method of magnifying small movement of the indicator in all mechanical comparators are effected by means of levers, gear trains or a combination of these elements.

Mechanical comparators are available having magnifications from 300 to 5000 to 1. These are mostly used for inspection of small parts machined to close limits.

Dial indicator

A dial indicator or dial gauge is used as a mechanical comparator. The essential parts of the instrument are like a small clock with a plunger projecting at the bottom as shown in fig.

Very slight upward movement on the plunger moves it upward and the movement is indicated by the dial pointer. The dial is graduated into 100 divisions.

A full revolution of the pointer about this scale corresponds to 1mm travel of the plunger. Thus, a turn of the pointer by one scale division represents a plunger travel of 0.01mm.

Experimental setup

The whole setup consists of worktable, dial indicator and vertical post. The dial indicator is fitted to vertical post by an adjusting screw as shown in fig. The vertical post is fitted on the worktable; the top surface of the work table is finely finished. The dial gauge can be adjusted vertically and locked in position by a screw.

Procedure

Let us assume that the required height of the component is 32.5mm. Initially this height is built up with slip gauges. The slip gauge blocks are placed under the stem of the dial gauge. The pointer in the dial gauge is adjusted to zero. The slip gauges are removed.

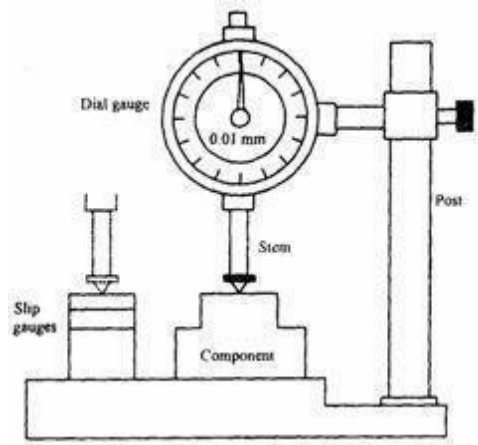

Now the component to be checked is introduced under the stem of the dial gauge. If there is any deviation in the height of the component, it will be indicated by the pointer.

Mechanism

The stem has rack teeth. A set of gears engage with the rack. The pointer is connected to a small pinion. The small pinion is independently hinged. i.e. it is not connected to the stem. The vertical movement of the stem is transmitted to the pointer through a set of gears. A spring gives a constant downward pressure to the stem.

READ TYPE MECHANICAL COMPARATOR

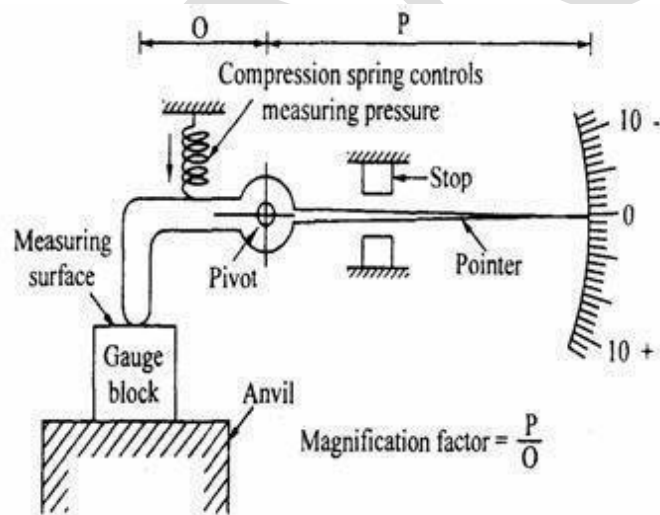

In this type of comparator, the linear movement of the plunger is specified by means of read mechanism. The mechanism of this type is illustrated in fig. A spring- loaded pointer is pivoted. Initially, the comparator is set with the help of a known dimension eg. Set of slip gauges as shown in fig. Then the indicator reading is adjusted to zero. When the part to be measured is kept under the pointer, then the comparator displays the deviation of this dimension either in \pm or $-$ side of the set dimension.

Advantages

- It is usually robust, compact and easy to handle.
- There is no external supply such as electricity, air required.
- It has very simple mechanism and is cheaper when compared to other types.
- It is suitable for ordinary workshop and also easily portable.

Disadvantages

- Accuracy of the comparator mainly depends on the accuracy of the rack and pinion arrangement. Any slackness will reduce accuracy.
- It has more moving parts and hence friction is more and accuracy is less.
- The range of the instrument is limited since pointer is moving over a fixed scale.

OPTICAL COMPARATOR

In this type of comparator, small plunger displacement is amplified by both mechanical and optical system. The amplification is first done by pivoted lever and then by a simple optical system.

Construction details

The optical comparator consists of the following parts such as

- (1) Pivoted lever
- (2) Objective lens
- (3) Scale
- (4) Plunger
- (5) Table and base
- (6) Mirror

Pivoted lever

The pivoted lever amplifies the plunger movement mechanically. It is pivoted near the plunger. One end is fitted with the plunger and other end is fitted with a mirror.

Objective lens

The main function of objective lens is to convert the incoming light rays from the source into parallel beams.

Screen and scale

It is a final display device from which the readings can be obtained. It is semitransparent glass.

Plunger

It is reciprocating member. During the measurement, the plunger actuates.

Table

The work is placed on the table to carry out the task.

Base

It is rigid support over which the table is mounted

Mirror

It reflects the incoming light rays from the source which is hinged at the other end of the lever.

Working Principle

During measurement, the vertical displacement of the plunger is magnified by the ratio of the lever arm. The lever tilts the mirror about its hinge to again magnify. The light rays from the lamp are condensed by a condensing lens. Then, the condensed light falls on the objective lens. The light rays are converted into parallel beams again the parallel beam of light ray fall on the mirror.

The mirror reflects the light rays on a screen. As the screen is the semi-transparent glass, the image of work placed on the table will be reflected. The magnified master drawing is placed over the screen. The projected image is compared with the master drawing. This type of comparator can also be used for inspecting small parts such as screw, thread, saw teeth etc. The differences amplified by a lever to give a vertical displacement and an angular displacement. The difference x between two dimensions may be used to actuate a lever to displace by y . Same displacement causes a ray of light which is initially at zero angle to get displaced by 2θ because the mirror is deflected by θ . The magnified reading is a measure of displacement x . The scale is calibrated by gauge blocks.

Advantages

- Small parts can also be inspected
- Different amplification can be obtained by adjusting the projection lens and the position of mirror.

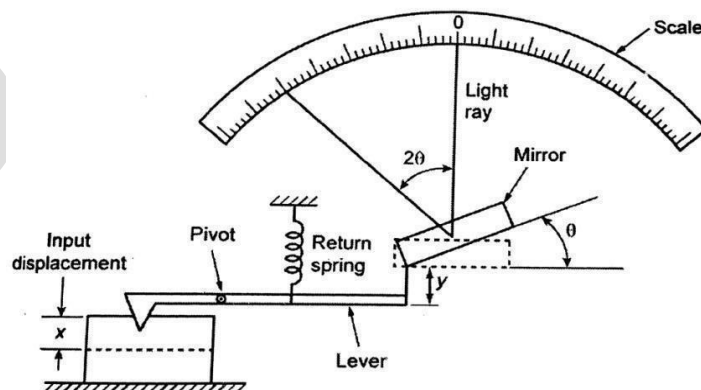

Pneumatic Comparator

In this system, no physical contact is made either with the setting gauge or the part being measured, and that internal dimensions may be readily measured, not only with respect to tolerance

boundaries, but also geometric form. Further, the system lends itself to the inspection of a single, or a number of dimensions simultaneously, either during or immediately after the operating cycle of a machine tool. Back-pressure (Pneumatic) comparator: It uses a water manometer for the indication of back pressure.

It consists of a vertical metal cylinder filled with water upto a certain level and a dip tube immersed into it upto a depth corresponding to the air pressure required. A calibrated manometer tube is connected between the cylinder and control orifice as shown in fig.. The air from its normal source of supply is filtered and passes through a flow valve.

Its pressure is then reduced and maintained at a constant value by a dip tube into a water chamber, the pressure value being determined by the head of the water displaced, excess air escaping to atmosphere. The air at reduced pressure then passes through the control orifice, and escapes from the measuring orifice. The back pressure in the circuit is indicated by the head of water displaced in the manometer tube.

The tube is graduated linearly to show changes of pressure resulting from changes in dimension 'd'. Amplifications of up to 50000 are obtainable with this system.

14. Explain the working principle of angle Dekkor with a neat sketch. Also write the applications of angle Dekkor. And also explain how the measurements are made in optical bevel protractor. (NOV/DEC 2014 & 2015, 2016)

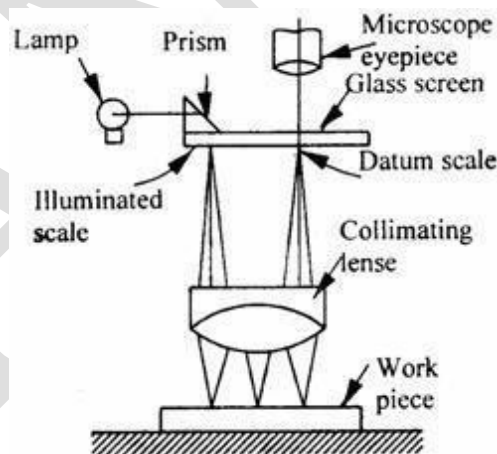

This is also a type of auto-collimator. There is an illuminated scale in the focal plane of the collimating lens.

This illuminated scale is projected as a parallel beam by the collimating lens which after striking a reflector below the instrument is refocused by the lens in the field of view of the eyepiece. In the field of view of microscope, there is another datum scale fixed across the center of screen.

The reflected image of the illuminated scale is received at right angle to the fixed scale as shown in fig. Thus the changes in angular position of the reflector in two planes are indicated by

changes in the point of intersection of the two scales. One division on the scale is calibrated to read 1 minute.

Uses of Angle Dekkor

Measuring angle of a component

Angle dekkor is capable of measuring small variations in angular setting i.e. determining angular tilt. Angle dekkor is used in combination with angle gauge. First the angle gauge combination is set up to the nearest known angle of the component.

Now the angle dekkor is set to zero reading on the illuminated scale. The angle gauge build up is then removed and replaced by the component under test.

Usually a straightedge being used to ensure that there is no change in lateral positions. The new position of the reflected scale with respect to the fixed scale gives the angular tilt of the component from the set angle.

Checking the slope angle of a V-block

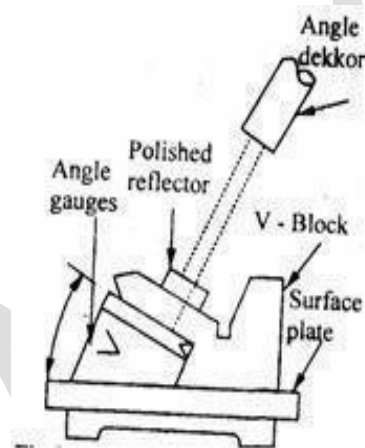

Figure shows the setup for checking the sloping angle of V block. Initially, a polished reflector or slip gauge is attached in close contact with the work surface. By using angle gauge zero reading is obtained in the angle dekkor. Then the angle may be calculated by comparing the reading obtained from the angle dekkor and angle gauge.

To measure the angle of cone or Taper gauge

Initially, the angle dekkor is set for the nominal angle of cone by using angle gauge or sine bar. The cone is then placed in position with its base resting on the surface plate. A slip gauge or reflector is attached on the cone since no reflection can be obtained from the curved surface. Any deviation from the set angle will be noted by the angle dekkor in the eye piece and indicated by the shifting of the image of illuminated scale.

OPTICAL BEVEL PROTRACTOR

Working Principle

The value can be measured to an accuracy of 2 min by using this type of bevel protractor. The values are obtained against an index line or vernier by means of an optical magnifying system. The optical magnifying system is attached with the bevel protractor itself.

A separate arrangement is provided for adjusting the focus of the system for the normal variation of eye sight. The vernier scale are arranged always in focus of the optical system.

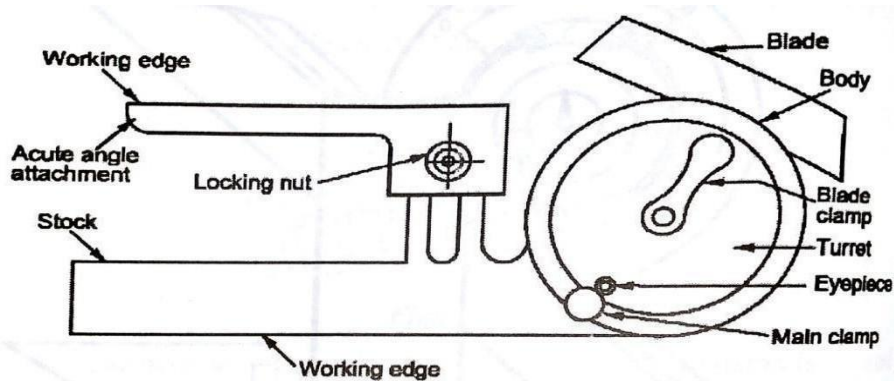

15. Explain the working principle of autocollimator and briefly explain its application.

NOV/DEC 2010, (APR/MAY 2017)

AUTO-COLLIMATOR

Auto-collimator is an optical instrument used for the measurement of small angular differences, changes or deflection, plane surface inspection etc. For small angular measurements, autocollimator provides a very sensitive and accurate approach. An auto-collimator is essentially an infinity telescope and a collimator combined into one instrument.

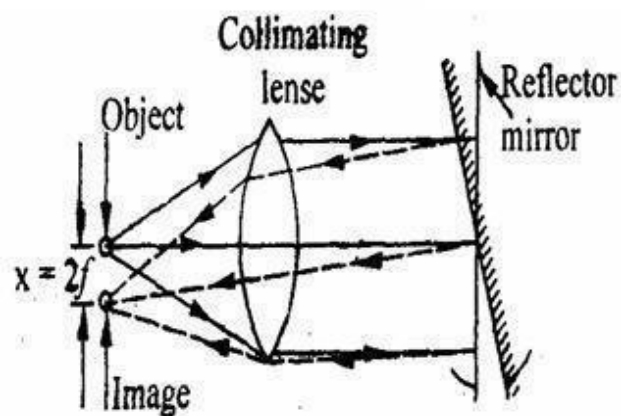

Basic principle

If a light source is placed in the focus of a collimating lens, it is projected as a parallel beam

of light. If this beam is made to strike a plane reflector, kept normal to the optical axis, it is reflected back along its own path and is brought to the same focus. The reflector is tilted through a small angle 'θ'. Then the parallel beam is deflected twice the angle and is brought to focus in the same plane as the light source.

The distance of focus from the object is given by

$$x = 2\theta \cdot f$$

Where, f = Focal length of the lens

θ = Tilted angle of reflecting mirror.

WORKING OF AUTO-COLLIMATOR:

There are three main parts in auto-collimator.

1. Micro meter microscope.
2. Lighting unit and
3. Collimating lens.

Figure shows a line diagram of a modern auto - collimator. A target graticule is positioned perpendicular to the optical axis. When the target graticule is illuminated by a lamp, rays of light diverging from the intersection point reach the objective lens via beam splitter. From objective, the light rays are projected as parallel rays to the reflector.

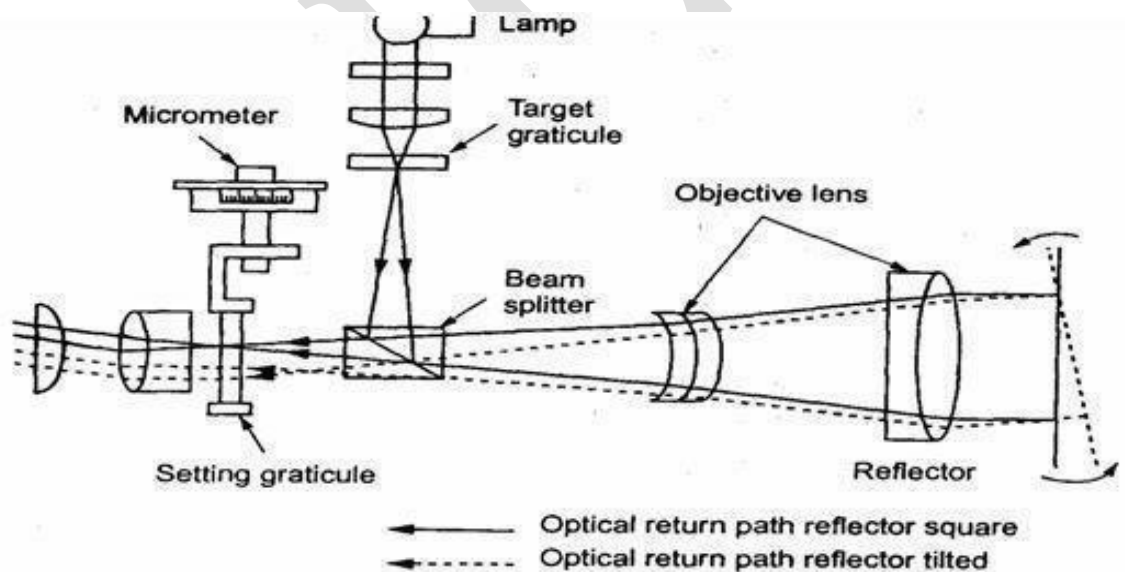

A flat reflector placed in front of the objective and exactly normal to the optical axis reflects the parallel rays of light back along their original paths. They are then brought to the target graticule and exactly coincide with its intersection. A portion of the returned light passes through the beam splitter and is visible through the eyepiece. If the reflector is tilted through a small angle, the reflected beam will be changed its path at twice the angle. It can also be brought to target graticule but linearly displaced from the actual target by the amount $2\theta \cdot f$. Linear displacement of the graticule image in the plane tilted angle of eye piece is directly proportional to the reflector. This can be measured by optical micrometer. The

photo electric auto- collimator is particularly suitable for calibrating polygons, for checking angular indexing and for checking small linear displacements.

APPLICATIONS OF AUTO-COLLIMATOR

Auto-collimators are used for

- 1) Measuring the difference in height of length standards.
- 2) Checking the flatness and straightness of surfaces.
- 3) Checking squareness of two surfaces.
- 5) Precise angular indexing in conjunction with polygons. Checking alignment or parallelism.
- 6) Comparative measurement using master angles.
- 7) Measurement of small linear dimensions.
- 8) For machine tool adjustment testing.

Part C

1. Explain the working principle of SINE BAR (APR/MAY 2017)

Sine bars are always used along with slip gauges as a device for the measurement of angles very precisely. They are used to

- Measure angles very accurately.
- Locate the work piece to a given angle with very high precision.

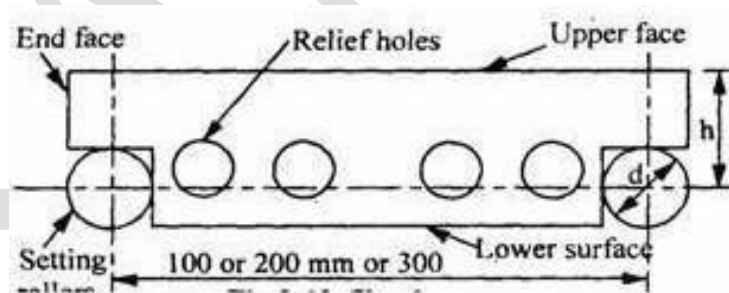

Fig 2.21 Sine Bar

Sine bars are made from high carbon, high chromium and corrosion resistant steel. These materials are highly hardened, ground and stabilized. In sine bars, two cylinders of equal diameter are attached at the ends with their axes mutually parallel to each other. They are also at equal distance from the upper surface of the sine bar. Mostly the distance between the axes of two cylinders is 100mm, 200mm or 300mm. The working surfaces of the rollers are finished to $0.2\mu\text{mR}$ value. The cylindrical holes are provided to reduce the weight of the sine bar.

Working principle of sine bar

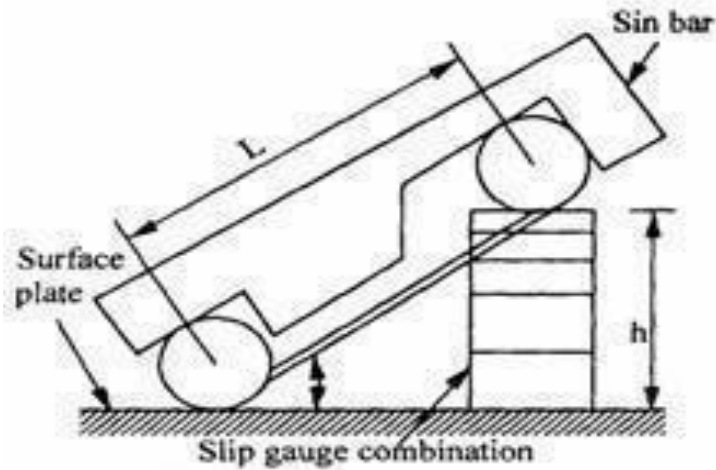

Fig 2.22 Principle of Sine bar

The working of sine bar is based on **trigonometry principle**. To measure the angle of a given specimen, one roller of the sine bar is placed on the surface plate and another one roller is placed over the surface of slip gauges. Now, 'h' be the height of the slip gauges and 'L' be the distance between roller centers,

$$\sin\theta = \frac{h}{L}$$

$$\therefore \theta = \sin^{-1} (h/L)$$

D) Calculate the tolerances, fundamental deviations and limits of sizes for the shaft designated as 40 H8/f7. Standard tolerances for IT7 is 16*i* and IT8 is 25*i*. Where 'i' is the standard tolerances unit. Upper deviation for 'f' shaft is $-5.5D^{0.41}$. 40 mm lies in the diameter range 30-50 mm.

Soln

$$D = \sqrt{30 \times 50} = 38.73 \text{ mm}$$

$$i = 0.45 \sqrt[3]{D} + 0.001D$$

$$= 0.45 \sqrt[3]{38.73} + 0.001 \times 38.73$$

$$i = 0.03873 \text{ micron}$$

Tolerances

$$IT_7 = 16i = 16 \times 0.03873 = 0.77 \text{ micron}$$

$$IT_8 = 25i = 25 \times 0.03873 = 1 \text{ micron}$$

Deviations

$$\text{Upper Deviation} = -5.5D^{0.41} = -5.5 \times 0.03873^{0.41}$$

$$= -24.63 \text{ micron}$$

$$\text{Lower deviation} = IT_7 + 0.63D = 0.77 \text{ micron} + 0.63 \times 38.73 \text{ mm}$$

$$= 25.019 \text{ micr}$$

Limits

Limits for shaft f7

$$H.L. \text{ of shaft} = 40 - 0.02 \text{ mm}$$

$$L.L. \text{ of shaft} = 40 - 0.02 - 0.00077$$

$$= 40^{-0.02077}$$

UNIT 3- ADVANCES IN METROLOGY

Part-A

1. Why is laser preferred in engineering metrology? (Nov 10)

It has high precision , accuracy , rapid non contact of gauging of soft,delicate or hot moving points.

2. Write the application of laser interferometer? (Nov 12)

Laser measurement and angular measurement.

3. List the various geometrical checks made on machine tools. (MAY 2014)

- Straightness of guide ways and slide ways of machine tool.
- Flatness of machine tables and slide ways.
- Parallelism, equidistance and alignment of the slide ways.
- True running and alignment of shaft and spindle.
- The pitch error or lead of lead screw.
- Pitch errors of gears.

4. Define straightness of axes? (Nov 13)

It is defined as the deviation from a straight line in two orthogonal planes for each axis movement and six measurements to be considered. Straight lines of x-axis are measured in y and z direction. Y-axis in x and z direction. Z-axis in x and y direction.

5. What are the benefits of using CMM? (Nov 14)Data communication

Digital input and output comment Minimize CNC programInterface to CAD software.

6. Write some features of CMM software. (NOV/DEC 2015)

Measurement of diameter, center distance can be measured as follows: 1. Measurement of plane and spatial curves 2. Minimize CNC programme. 3. Data communications. 4. Digital input and output command 5. Interface to CAD software.

7. Define machine vision.(May'14)

Machine vision can be defined as a means of simulating the image recognition and analysis capabilities of the human system with electronic andelectromechanical techniques.

8. What are the four basic types of machine, vision system?

- (i) Image formation.
- (ii) Processing of image.(iii) Analyzing the image
- (iv) Interpretation of image.

9. Write the advantages of CMM. (NOV/DEC 2013)

- (i) Quicker inspection
- (ii) Accurate measurements
- (iii) Easier to position
- (iv) More accurate

10. What are advantages of laser interferometer. (NOV/DEC 2014)

- (i) Suited for measuring linear positioning, straightness in to two planes
- (ii) Long covering range and high sensitivity
- (iii) Free from noise disturbance
- (iv) Non-contact measurement is possible

11. Differentiate between straightness and flatness. (April/May 2016)

Straightness is defined as a line where all elements of a line are collinear but flatness is the minimum distance between two planes within all points on a surface.

12. What is diffraction grating. (Nov/Dec 2015)

Diffraction grating is an optical component with a periodic structure, which splits and diffracts light into several beams travelling in different directions.

13. Differentiate between Rt and Rz. (April/May 2015)

Stylus (X, Y) R_t , the Maximum Profile Height Along (X,Y), is determined from the difference between the highest peak and lowest valley found along the evaluation length.

Stylus (X,Y) R_z , the Average Maximum Profile Height Along (X,Y), is derived from the average, over all cutoff lengths (i.e. sampling lengths), of the difference between the highest peak and lowest valley.

14. Why laser is used as light source in interferometers? (Nov Dec 2016)

Laser is used as light source in interferometers because Laser light has four unique characteristics that differentiate it from ordinary light: these are

- Coherence
- Directionality
- Monochromatic
- High intensity

15. Name the different stages involved in the machine vision based measurement. (Nov Dec 2016)

- Image Acquisition
- Image Processing or Image Enhancement
- Image Segmentation

- Image Analysis
- Model Matching or Pattern Recognition

16. What is mean by “Qualifying the Tip” in CMMs?(April May 2017)

Tip Qualification uses the tip estimate to determine whether the tip is acceptable for use. This feature can be used to check tips periodically for signs of wear, and to exchange unacceptably worn tips. By using tip qualification to enforce tip acceptance criteria, metrological values can be compared from image to image, ensuring consistent, long-term comparability of samples.

17. Write any 4 applications of artificial vision systems in manufacturing industries. (April May 2017)

- Automatic inspection, e.g., in manufacturing applications;
- Assisting humans in identification tasks, e.g., a species identificationsystem
- Controlling processes, e.g., an industrial robot;
- Navigation, e.g., by an autonomous vehicle or mobile robot; and

Part-B

1. Explain the construction and working of a laser telemetric systemwith a neat sketch. (NOV/DEC 2012)

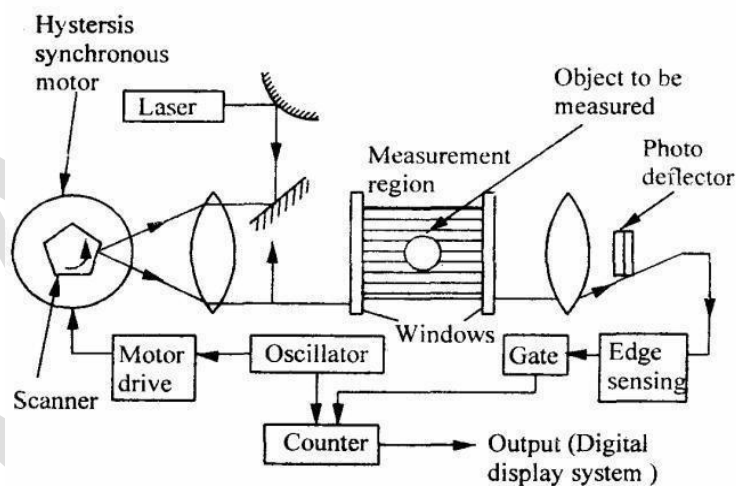

Laser telemetric system is an on-contact gauge that measures with a collimated laser beam. It measures at the rate of 150 scans per second. It basically consists of three components, a transmitter, a receiver and processor electronics.

The transmitter module produces a collimated parallel scanning laser beam moving at a high constant, linear speed. The scanning beam appears as a line. The receiver module collects and photo electrically senses the laser light transmitted past the object being measured.

The processor electronics takes the received signals to convert them into a convenient form and displays the dimension being gauged. The transmitter contains a low power helium - neon gas

laser and its power supply, a specially designed collimating lens, a synchronous motor, a multifaceted reflector prism, a synchronous pulse photo detector and a protective replaceable window.

The high speed of scanning permits online gauging and thus it is possible to detect changes in dimensions when components are moving on a continuous product such as in rolling process moving at very high speed. There is no need of waiting or product to cool for taking measurements. This system can also be applied on production machines and control then with closed feedback loops. Since the output of this system is available in digital form, it can run a process controller limit alarms can be provided and output can be taken on digital printer.

2. Explain the working of AC laser interferometer? (NOV/DEC 2014, 2016, 2017)

It is possible to maintain the quality of interference fringes over longer distance when lamp is replaced by a laser source. Laser interferometer uses AC laser as the light source and the measurements to be made over longer distance. Laser is a monochromatic optical energy, which can be collimated into a directional beam AC. Laser interferometer (ACLI) has the following advantages.

- High repeatability
- High accuracy
- Long range optical path
- Easy installations
- Wear and tear

Schematic arrangement of laser interferometer is shown in fig. Two- frequency Zeeman laser generates light of two slightly different frequencies with opposite circular polarization. These beams get split up by beam splitter B_1 one part travels towards Band from there to external cube corner here the displacement is to be measured.

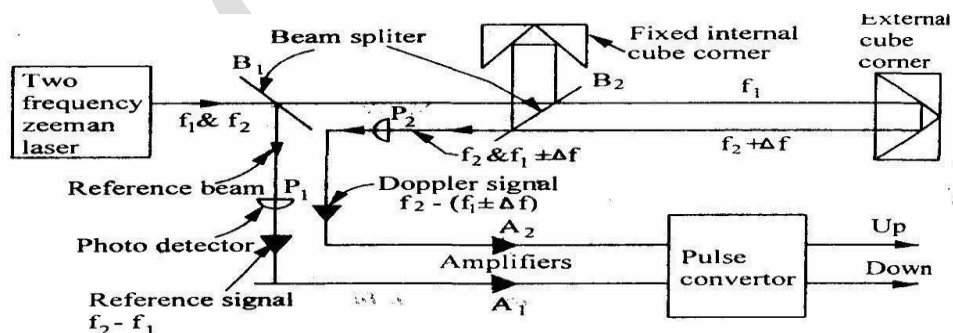

Laser Interferometer

This interferometer uses cube corner reflectors which reflect light parallel to its angle of incidence. Beam splitter B_2 optically separates the frequency J which alone is sent to them movable cube corner reflector. The second frequency from B_2 is sent to a fixed reflector which then rejoins f_1 at the beam splitter B_2 to produce alternate light and dark interference flicker at about 2 Mega

cycles per second. Now if the movable reflector moves, then there turning beam frequency Doppler - shifted slightly up or down by Δf . Thus the light beams moving towards photo detector P2 have frequencies f_2 and $(f_1 \pm \Delta f_1)$ and P2 changes these frequencies into electrical signal. Photo detector P2 receive signal from beam splitter B2 and changes the reference beam frequencies f_1 and f_2 into electrical signal. An AC amplifier A separates frequency. Difference signal $f_2 - f_1$ and A2 separates frequency difference signal. The pulse converter extract signal. One cycle per half wave length of motion. The up - down pulses are counted electronically and displayed in analog or digital form.

3. Explain the working principle of a Michelson Interferometer with a neat sketch. (NOV/DEC 2015)

Michelson interferometer consists of a mono chromatic light source a beam splitter and two mirrors. The schematic arrangement of Michelson interferometer is shown in fig. The monochromatic light falls on a beam splitter, which splits the light into two rays of equal intensity at right angles. One ray is transmitted to mirror M1 and other is reflected through beam splitter to mirror M2. From both these mirrors, the rays are reflected back and these return at the semi reflecting surface from where they are transmitted to the eye. Mirror M2 is fixed and mirror M1 is movable. If both the mirrors are at same distance from beam splitter, then light will arrive in phase and observer will see bright spot due to constructive interference. If movable mirror shifts by quarter wavelength, then beam will return to observer 180° out of phase and darkness will be observed due to destructive interference.

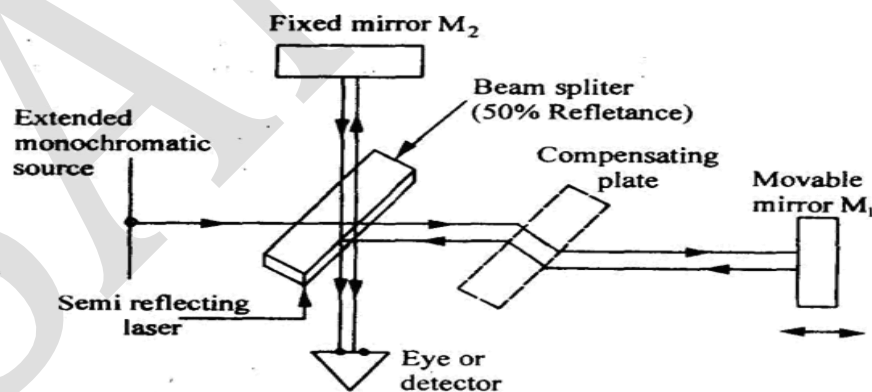

Michelson Interferometer

Each half - wavelength of mirror travel produces a change in the measured optical path of one wave length and the reflected beam from the moving mirror shifts through 360° phase change. When the reference beam reflected from the fixed mirror and the beam reflected from the moving mirror rejoin at the beam splitter, they alternately reinforce and cancel each other as the mirror moves. Each cycle of intensity at the eye represent $\lambda/2$ of mirror travel. When white light source is

used then a compensator plate is introduced in each of the path of mirror M1 So that exactly the same amount of glass is introduced in each of the path.

To improve the Michelson interferometer

- Use of laser the measurements can be made over longer distances and highly accurate measurements when compared to other mono chromatic sources.
- Mirrors are replaced by cube - corner reflector which reflects light parallel to its angle of incidence.
- Photo cells are employed which convert light intensity variation in voltage pulses to give the amount and direction of position change.

4. Discuss the need, types and constructional features of coordinate measuring machine. (NOV/DEC 2013,2016)

Measuring machines are used for measurement of length over the outer surfaces of a length bar or any other long member. The member may be either rounded or flat and parallel. It is more useful and advantageous than vernier calipers, micrometer, screw gauges etc. the measuring machines are generally universal character and can be used for works of varied nature. The co-ordinate measuring machine is used for contact inspection of parts. When used for computer-integrated manufacturing these machines are controlled by computer numerical control. General software is provided for reverse engineering complex shaped objects. The component is digitized using CNC, CMM and it is then converted into a computer model which gives the two surface of the component. These advances include for automatic work part alignment on the table. Savings in inspection 5 to 10 percent of the time is required on a CMM compared to manual inspection methods.

Types of Measuring Machines

1. Length bar measuring machine.
2. New all measuring machine.
3. Universal measuring machine.
4. Co-ordinate measuring machine.
5. Computer controlled co-ordinate measuring machine.

Constructions of CMM

Co-ordinate measuring machines are very useful for three dimensional measurements. These machines have movements in X-Y-Z co-ordinate, controlled and measured easily by using touch probes. These measurements can be made by positioning the probe by hand, or automatically in more expensive machines. Reasonable accuracies are 5 micron. Or 1 micro meter. The method these machines work on is measurement of the position of the probe using linear position sensors.

These are based on more fringe patterns (also used in other systems). Transducer is provided in tilt directions for giving digital display and senses positive and negative direction.

Types of CMM

a. Cantilever type

The cantilever type is very easy to load and unload, but mechanical error takes place because of sag or deflection in Y-axis.

b. Bridge type

Bridge type is more difficult to load but less sensitive to mechanical errors.

c. Horizontal boring Mill type

This is best suited for large heavy work pieces.

(iv) Vertical boring mill type: -

Vertical boring mill is highly accurate but slower to operate.

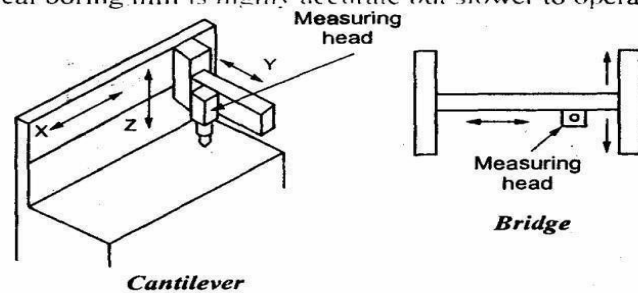

(Measuring head movement in plane perpendicular to paper)

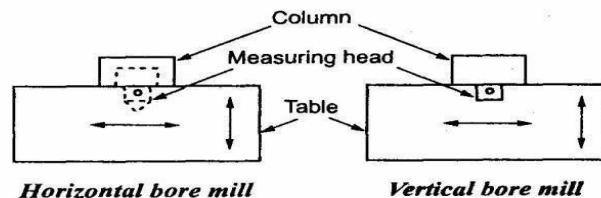

Types of CMM

Working Principle

CMM is used for measuring the distance between two holes. The work piece is clamped to the work table and aligned for three measuring slides x, y and z. The measuring head provides a probe tip which is seated in first datum hole and the position of probe digital read out is set to zero. The probe is then moved to successive holes, the read out represents the co-ordinate part print hole location with respect to the datum hole. Automatic recording and data processing units are provided to carry out complex geometric and statistical analysis. Special co-ordinate measuring machines are provided both linear and rotary axes. This can measure various features of parts like cone, cylinder and hemisphere. The prime advantage of co-ordinate measuring machine is the quicker inspection and accurate measurements.

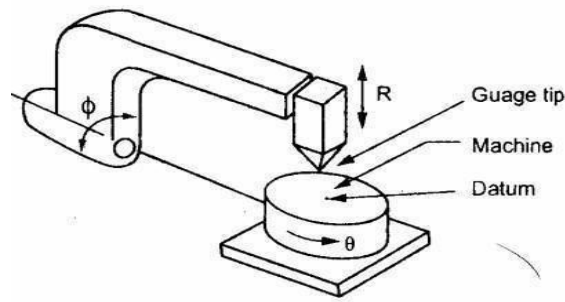

5. Define machine vision. Name the four types of machine vision system (NOV/DEC 2015)

The schematic diagram of a typical vision system is shown. This system involves image acquisition; image processing. Acquisition requires appropriate lighting. The camera and store digital image processing involves manipulating the digital image to simplify and reduce number of data points. Measurements can be carried out at any angle along the three reference axes x y and z without contacting the part. The measured values are then compared with the specified tolerance which stores in the memory of the computer.

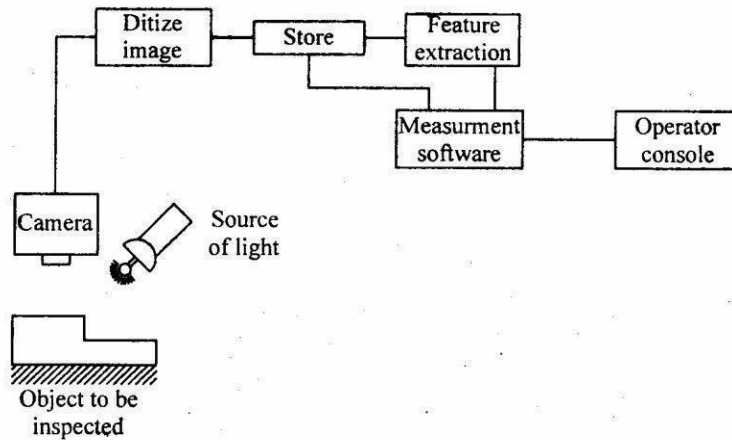

Machine Vision

The main advantage of vision system is reduction of tooling and fixture costs, elimination of need for precise part location for handling robots and integrated automation of dimensional verification and defect detection.

Principle

Four types of machine vision system and the schematic arrangement is shown

- (i) Image formation.
- (ii) Processing of image in a form suitable for analysis by computer.
- (iii) Defining and analyzing the characteristic of image.

(iv) Interpretation of image and decision-making.

For formation of image suitable light source is required. It consists of incandescent light, fluorescent tube, fiber optic bundle, and arc lamp. Laser beam is used for triangulation system for measuring distance. Ultraviolet light is used to reduce glare or increase contrast. Proper illumination back lighting, front lighting, structured light is required. Back lighting is used to obtain maximum image contrast. The surface of the object is to be inspected by using front lighting. For inspecting three-dimensional feature structured lighting is required. An image sensor vidicon camera, CCD camera is used to generate the electronic signal representing the image. The image sensor collect slight from the scene through a lens, using photo sensitive target, converts into electronic signal.

Vidicon camera

Image is formed by focusing the incoming light through a series of lenses on to the photo conductive face plate of the vidicon tube. The electron beam scans the photo conductive surface and produces an analog voltage proportional to the variation in light intensity for each scan line of the original scene.

Solid-state camera

The image sensors charge coupled device (CCD) contain matrix of small array, photo sensitive elements accurately spaced and fabricated on silicon chips using Integrated circuit technology. Each detect or converts into analog signal corresponding to light intensity through the camera lens.

Image processor

A camera may form an image 30 times per sec at 33m sec intervals. A teach time interval the entire image frozen by an image processor for processing. An analog to digital converter is used to convert analog voltage of each detector into digital value. If voltage level for each pixel is given by either 0 or 1 depending on threshold value. It is called binary system on the other hand grey scale system assigns up to 256 different values depending on intensity to each pixel. Grey scale requires higher degree of image refinement, huge storage processing capability. For analysis 256 x 256 pixels image array up to 256 different pixel values will require 65000-8 bit storage locations at a speed of 30 images per second. Techniques windowing and image restoration are involved.

Windowing

Processing is the desired area of interest and ignores non-interested part of image.

Image restoration

Preparation of image during the pre-processing by removing the degrade. Blurring of lines,

poor contrast between images and presence of noise are the degrading.

The quality may be improved

- 1) By improving the contrast by brightness addition.
- 2) By increasing the relative contrast between high and low intensity elements.
- 3) By Fourier domain processing.
- 4) Other techniques to reduce edge detection and runlength encoding.

Image Analysis

Digital image of the object formed is analyzed in the central processing Unit of the system. Three important tasks performed by machine vision system are measuring the distance of an object from a vision system camera, determining object orientation and defining object position. The distance of an object from a vision system camera can be determined by triangulation technique. The object orientation can be determined by the methods of equivalent ellipse. The image can be interpreted by two-dimensional image. For complex three-dimensional objects boundary locations are determined and the image is segmented into distinct region.

Image Interpretation

This involves identification of an object. In binary system, the image is segmented on the basis of white and black pixels. The complex images can be interpreted by grey scale technique and algorithms. The most common image interpretation is template matching.

Function of Machine Vision

- Lighting and presentation of object to be evaluated.
- It has great impact on repeatability, reliability and accuracy.
- Lighting source and projection should be chosen and give sharp contrast.
- Image sensor compressor TV camera may be vidicon or solid state.
- For simple processing, analog comparator and a computer controller to convert the video information to a binary image is used.
- Data compactor employs a high speed away processor to provide high speed processing of the input image data.
- System control computer communicates with the operator and makes decision about the part being inspected.
- The output and peripheral devices operate the control of the system. The output enables the vision system to either control a process or provide caution and orientation information to a

robot, etc.

- These operate under the control of the system control of computer.

Applications

- Machine vision can be used to replace human vision for welding. Machining and maintained relationship between tool and work piece and assembly of parts to analyze the parts.
- This is frequently used for printed circuit board inspection to ensure minimum conduction width and spacing between conductors. These are used for weld seam tracking, robot guidance and control, inspection of microelectronic devices and tooling, online inspection in machining operation, assemblies monitoring high-speed packaging equipment etc.
- It gives recognition of an object from its image. These are designed to have strong geometric feature interpretation capabilities and handling equipment.

Part C

1. Explain the working of DC laser interferometer? (NOV/DEC 2015)

The recombined beam at beam splitter consists of two superimposed beams of different polarization. One component vertically polarized having travelled around reference arm and other component horizontally polarized having travelled around the measurement arm. These two beams being differently polarised do not interfere. The recombined beam then passes through a quarter wave plate which causes the two beams to interfere with one another to produce a beam of plane polarised light. The angular orientation of the plane of this polarized light depends on the phase difference between the light in the two returned beams. The direction of plane of polarisation spin is dependent on the direction of movement of the moving retro reflector. The beam after quarter wave plate is split into three polarization sensitive detectors. As the plane of polarised light spins, each detector produces a sinusoidal output wave form.

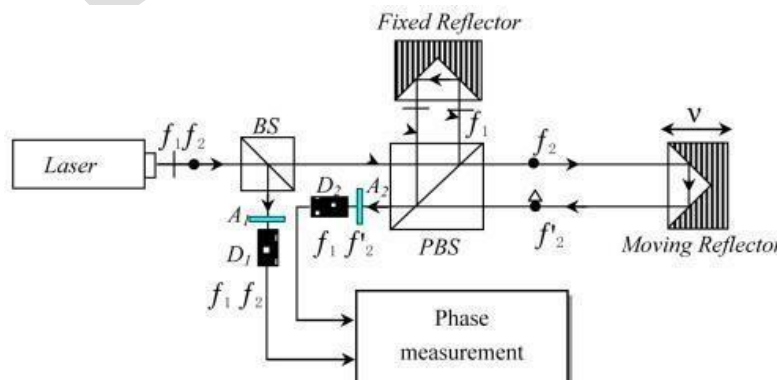

The polarisation sensitivity of the detectors can be set so that their outputs have relative phases of 0° , 90° , and 180° . The outputs of three detectors can be used to distinguish the direction of movement and also the distance moved by the moving retro reflector attached to the surface whose displacement is to be measured. For linear measurements (positional accuracy or velocity), the retro reflector is attached to the body moving along the linear axis. For angular measurement. For pitch and yaw), the angular beam splitter is placed in the path between the laser head and the angular reflector. In this way it is possible to measure flatness, straightness, rotary axis calibration. Arrangements also need to be made for environmental compensation because the refractive index of the air varies with temperature, pressure and humidity. Heterodyne interferometer, A.C device avoids all the problems encountered in above d.c. device, i.e. effect of intensity level change of source, fringe contrast changes and d.c. level shifts which can cause fringe miscounting. Interferometry is now an established and well developed technique for high accuracy and high resolution measurement.

2. With neat diagram explain the working principle of touch trigger probe.

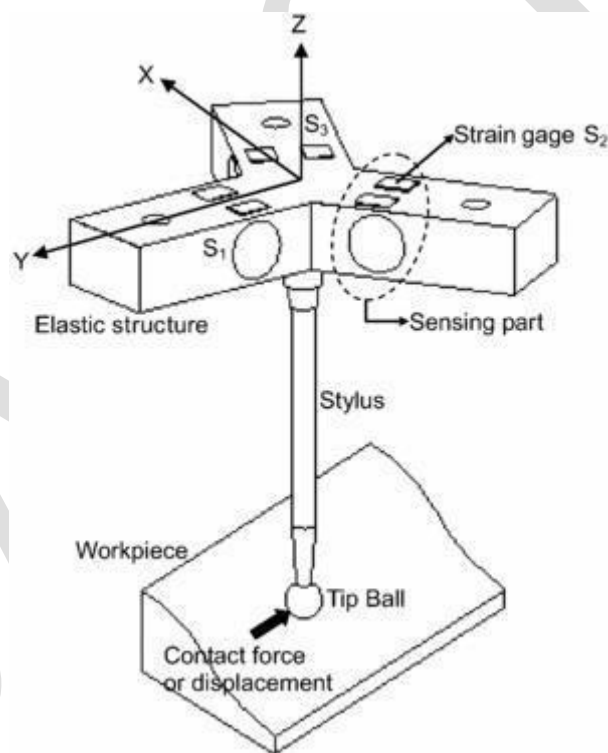

Tough trigger probes are widely used on most commercial coordinate measuring machines (CMMs). However, the CMMs with these probes have a systematic error due to the shape of the probe tip and elastic deformation of the stylus resulting from contact pressure with the specimen. In this paper, a new touch probe with a three degrees-of-freedom force sensor is proposed. From relationships between an obtained contact force vector and the geometric shape of the probe, it is possible to calculate the coordinates of the exact probe– specimen contact points. An empirical model of the probe is applied to calculate the coordinates of the contact points and the amount of pretravel. With the proposed probing system, the measuring error induced by the indeterminateness

of the probe–specimen contact point and the pre travel can be estimated and compensated for successfully.

Strain Gauges

Strain Gauge probe technology is now appearing on the market and has become widely accepted as a more accurate solution over the traditional kinematic probes. On contact with the work piece, the stylus is deflected as the force is applied to the sensor. The benefits of this system are twofold: first, much greater form accuracy is possible, and secondly, inaccuracies due to styli length are drastically reduced as precision is only minutely affected by varying styli lengths. The bottom line is enhanced accuracy on your coordinate measuring machine.

Scanning Probes

Scanning probes provide continuous deflection output that can be synchronized with the position of the DCC CMM. Data is gathered during movement when the stylus is brought into contact with the component to be measured and then moved along the surface of the feature. By using this technique, deflection of the probe is kept within tight tolerance boundaries thereby ensuring maximum accuracy.

Application and Benefits

There are, in fact, several different types of scanning probes, analogue and optical systems prevalent in the market today. We must therefore have an understanding of the benefits a scanning probe provides the CMM technician. These probes are best used when measuring parts that consist of complex surfaces and because scanning often occurs at speeds of over 300 mm per second, gathering data quickly is no problem. Form deviation is another target for the scanning probe. Features such as cylinders, planes and conical shapes can be measured with extreme precision whilst reporting accurate deviation of the feature's form.

UNIT 4
FORM MEASUREMENT

Part-A

1. Mention the purpose of Goniometric heads in tool makers microscope? (May 12)

Goniometric head in tool makers microscope is used to measure circular divisions .for example, the flank angle of the gears may be measured using Tool makers microscope with a goniometric head.

2. What is meant by 'Best size wire' in screw thread measurement?(May 16)

Best size of wire is a wire of such diameter that it makes contact with flanks of the thread on the pitch line.

3. What are the factors affecting surface roughness? (May 16,Nov 16)

- (a) Vibration
- (b) Material of the work piece
- (c) Tool
- (d) Machining type.

4. Define degree of fullness and degree of emptiness in form factor.(Dec 13)

Degree of fullness is the ratio of area of metal considered to the area of enveloping the rectangle.

Degree of emptiness is the ratio between the difference of the area of metal considered to the area of enveloping the rectangle and area of enveloping the rectangle.

5. Define straightness of line in two planes?(MAY/JUNE 14)

A line is said to be straight over a given length if the variation of the distance of its points from two planes perpendicular to each other and parallel to the direction of a line remaining within the specified tolerance limits.

6. Define roundness and name the four measurements of roundness?(Dec14)

It is a surface of the revolution where all surfaces are intersected by any plane perpendicular to a common axis in case of cylinder and cone.

- a. Maximum inscribed circle
- b. Minimum radial separation circle
- c. Maximum inscribed circle
- d. Minimum circumscribed circle.

7. What is gear run out?(Dec 12)

It means eccentricity in the pitch circle. It will produce periodic vibration during each revolution

of the gear. It will give the tooth failure in gears.

8. List the reasons for the occurrence of progressive pitch errors in screwthreads? (Dec 12)

- a. In correct linear and angular velocity ratio
- b. In correct gear train and lead screw
- c. Saddle fault

9. Define Lead?(Dec 13)

It is defined as the distance at which a thread advances for one rotation. $\text{Lead} = \text{No. of starts} \times \text{Pitch}$

10. Define lead angle?(Dec 13)

It is the angle between the tangent to the helix and plane perpendicular to the axis of cylinder.

11. What are the various methods used for measuring the gear tooth thickness?(May 14)

- a. Gear tooth vernier
- b. Constant chord method
- c. Base tangent method
- d. Measurement over pins.

12. Define constant chord?(May 12)

Constant chord is the chord joining points or opposite faces of the tooth.

13. Define straightness of a line in two planes?(May 14)

A line is said to be straight over a given length if the variation of the distance of its points from two planes perpendicular to each other and parallel to the direction of a line remaining within the specified tolerance limits.

14. Define drunken thread

A condition in which the crest of a thread or threads wavers or is uneven

15. What are the various factors affecting surface roughness of the machined components?

- Vibration of the machine tool
- In proper clamping of work piece
- Over depth of cut / feed rate

16. Is assessment length greater/ lesser than traverse length in surface finish measurement? Why?

The assessment length or evaluation length is the length of data that will be used for analysis. Commonly one sampling length is discarded from each end of the measurement length.

The measurement length is dictated by the numerical value of the cut-off, which itself is dictated by the type of surface inspection. Typically, a measurement may consist of a traverse of 6-7 times the cut-off selected. For example, 7 cut-offs at 0.8mm = 5.6mm. One of two cut-offs will then be removed according to the filter type and the remaining cut-offs used for assessment. This only applies when measuring roughness.

Part-B

1. Explain in detail the various methods used for checking the profile of a spur gear Profile checking.

The methods used for profile checking is

- Optical projection method.
- In volute measuring machine.

Optical projection method:

The profile of the gear projected on the screen by optical lens and then projected value is compared with master profile.

In volute measuring machine:

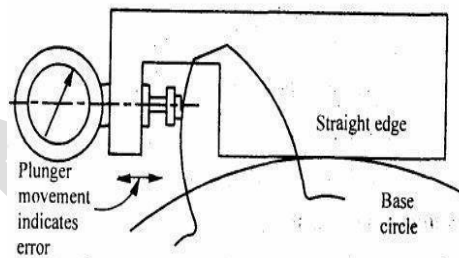

Involute Measuring Machine

In this method the gear is held on a mandrel and circular disc of same diameter as the base circle of gear for the measurement is fixed on the mandrel. After fixing the gear in the mandrel, the straight edge of the instrument is brought in contact with the base circle of the disc. Now, the gear and disc are rotated and the edge moves over the disc without slip. The stylus moves over the tooth profile and the error is indicated on the dial gauge.

2. Explain in detail the various methods used to measure the pitch of a spur gear

Pitch measurement:

There are two ways for measuring the pitch.

- Point to point measurement (i.e. One tooth point to next tooth point)
- Direct angular measurement

Tooth to Tooth measurement

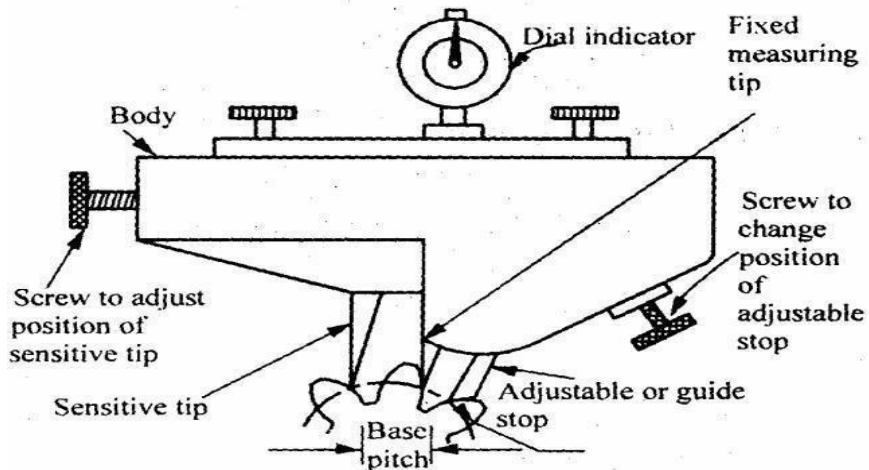

The instrument has three tips. One is fixed measuring tip and the second is sensitive tip, whose position can be adjusted by a screw and the third tip is adjustable or guide stop. The distance between the fixed and sensitive tip is equivalent to base pitch of the gear. All the three tips are contact the tooth by setting the instrument and the reading on the dial indicator is the error in the base pitch.

Direct Angular Measurement

It is the simplest method for measuring the error by using set dial gauge against a tooth. In this method the position of a suitable point on a tooth is measured after the gear has been indexed by a suitable angle. If the gear is not indexed through the angular pitch the reading differs from the original reading. The difference between these is the cumulative pitch error.

3. Explain how straightness is measured using the following instruments

The straightness of any surface could be determined by either of these instruments by measuring the relative angular positions of number of adjacent sections of the surface to be tested. First straight line is drawn on the surface then it is divided into a number of sections the length of each section being equal to the length of spirit level base or the plane reflector's base in case of auto collimator. The bases of the spirit level block or reflector are fitted with two feet so that only feet have line contact with the surface and the surface of base does not touch the surface to be tested.

The angular division obtained is between the specified two points. Length of each section must be equal to distance between the center lines of two feet. The special level can be used only for the measurement of straightness of horizontal surfaces while auto-collimator can be used on surfaces are any plane.

In case of spirit level, the block is moved along the line equal to the pitch distance between the center line of the feet and the angular variation of the direction of block. Angular variation can

be determined in terms of the difference of height between two points by knowing the least count of level and length of the base.

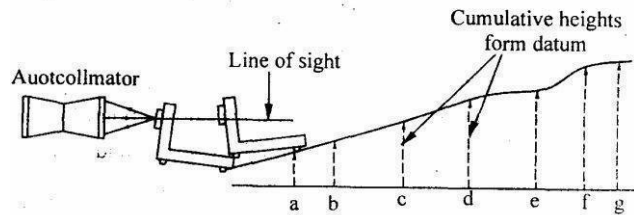

Straightness using Auto-Collimator

In case of auto collimator the instrument is placed at a distance of 0.5 to 0.75m from the surface to be tested. The parallel beam from the instrument is projected along the length of the surface to be tested. A block fixed on two feet and fitted with a plane vertical reflector is placed on the surface and the reflector face is facing the instrument.

The image of the cross wires of the collimator appears nearer the center of the field and for the complete movement of reflector along the surface straight line the image of cross wires will appear in the field of eyepiece. The reflector is then moved to the other end of the surface in steps equal to. The center distance between the feet and the tilt of the reflector is noted down in second from the eyepiece.

4. Explain the following direct methods of surface finish measurements.(NOV/DEC 2015)

- i) Taylor Hobson Talysurf

Talyor-Hobson-Talysurf

It is working a carrier modulating principle and it is an accurate method comparing with the other methods. The main parts of this instrument is diamond stylus (0.002mm radius) and skid

Principle

The irregularities of the surface are traced by the stylus and the movement of the stylus is converted into changes in electric current.

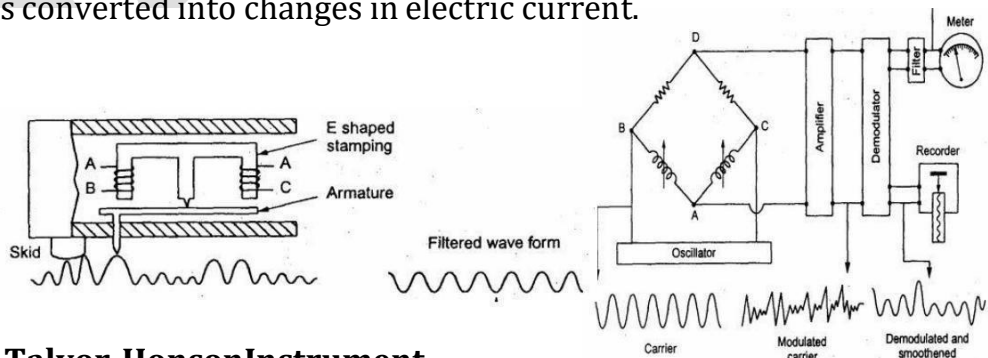

Talyor-HonsonInstrument

Working

On two legs of the E- shaped stamping there are coils for carrying an A.C. current and these coils form an oscillator. As the armature is pivoted about the central leg the movement of the stylus

causes the air gap to vary and thus the amplitude is modulated. This modulation is again demodulated for the vertical displacement of the stylus. So this demodulated output is move the pen recorder to produce a numerical record and to make a direct numerical assessment.

Tomlinson Surface meter

This instrument uses mechanical-cum-optical means for magnification.

Construction

In this the diamond stylus on the surface finish recorder is held by spring pressure against the surface of a lapped cylinder. The lapped cylinder is supported one side by probe and other side by rollers. The stylus is also attached to the body of the instrument by a leaf spring and its height is adjustable to enable the diamond to be positioned and the light spring steel arm is attached to the lapped cylinder. The spring arm has a diamond scribe at the end and smoked glass is rest on the arm.

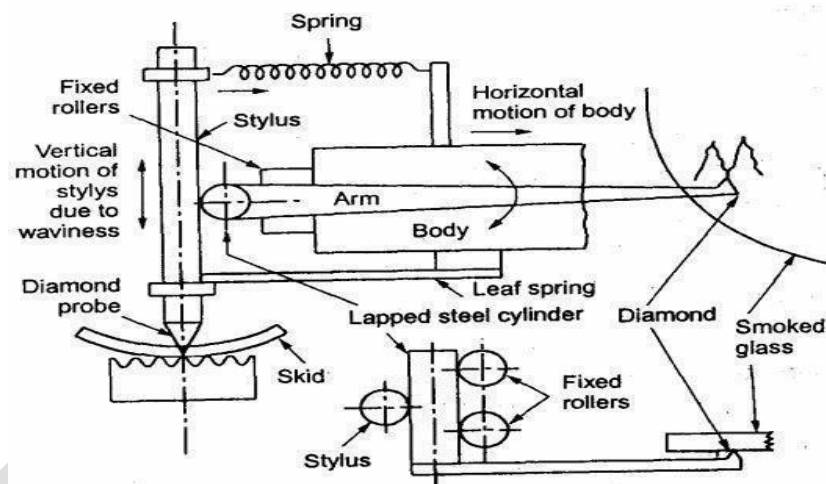

Tomlinson Surface meter

Working

When measuring surface finish the body of the instrument is moved across the surface by a screw rotation. The vertical movement of the probe caused by the surface irregularities makes the horizontal lapped cylinder to roll. This rolling of lapped cylinder causes the movement of the arm. So this movement induces the diamond scribe on smoked glass. Finally the movement of scribe together with horizontal movement produces a trace on the smoked glass plate and this trace is magnified by an optical projector.

5. Explain the tooth thickness measurement for the following methods. (APRIL/MAY 2016,2017) (NOV/DEC2016)

Tooth thickness is generally measured at pitch circle and also in most cases the chordal thickness measurement is carried out i.e. the chord joining the intersection of the tooth profile with the pitch circle.

The methods which are used for measuring the gear tooth thickness is

- a) Gear tooth vernier caliper method (Chordal thickness method)
- b) Base tangent method.
- c) Constant chord method.
- d) Measurement over pins or balls.

Gear tooth vernier method

In gear tooth vernier method the thickness is measured at the pitch line. Gear tooth thickness varies from the tip of the base circle of the tooth, and the instrument is capable of measuring the thickness at a specified position on the tooth. The tooth vernier caliper consists of vernier scale and two perpendicular arms. In the two perpendicular arms one arm is used to measure the thickness and other arm is used to measure the depth. Horizontal vernier scale reading gives chordal thickness (W) and vertical vernier scale gives the chordal addendum. Finally the two values compared.

The theoretical values of W and d can be found out by considering one tooth in the gear and it can be verified. In fig noted that w is a chord ADB and tooth thickness is specified by AEB . The distance d is noted and adjusted on instrument and it is slightly greater than addendum CE .

∴ ' W ' is chordal thickness and ' d ' is named as chordal addendum.

$$\text{So, } W = AB = 2AD$$

$$\text{And angle, } \angle AOD = \theta = \frac{360}{4n}$$

Where, n = Number of teeth.

$$W = 2AD = 2 \times AO \sin \theta$$

$$= 2R \sin \frac{360}{4n} \dots\dots$$

Where, R = Pitch circle radius

$$\text{Module, } m = \frac{P.C.D}{\text{No. of teeth}} = \frac{2R}{n}$$

$$\therefore R = \frac{nm}{2}$$

$$\text{And } OD = R \cos \theta = \frac{nm}{2} \cos \left(\frac{90}{n} \right)$$

$$\boxed{OD = \frac{nm}{2} \cos \left(\frac{90}{n} \right)}$$

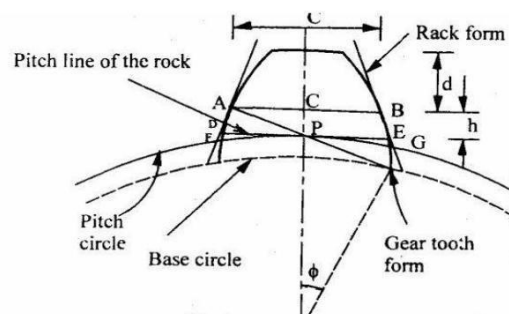

The Base Tangent Method

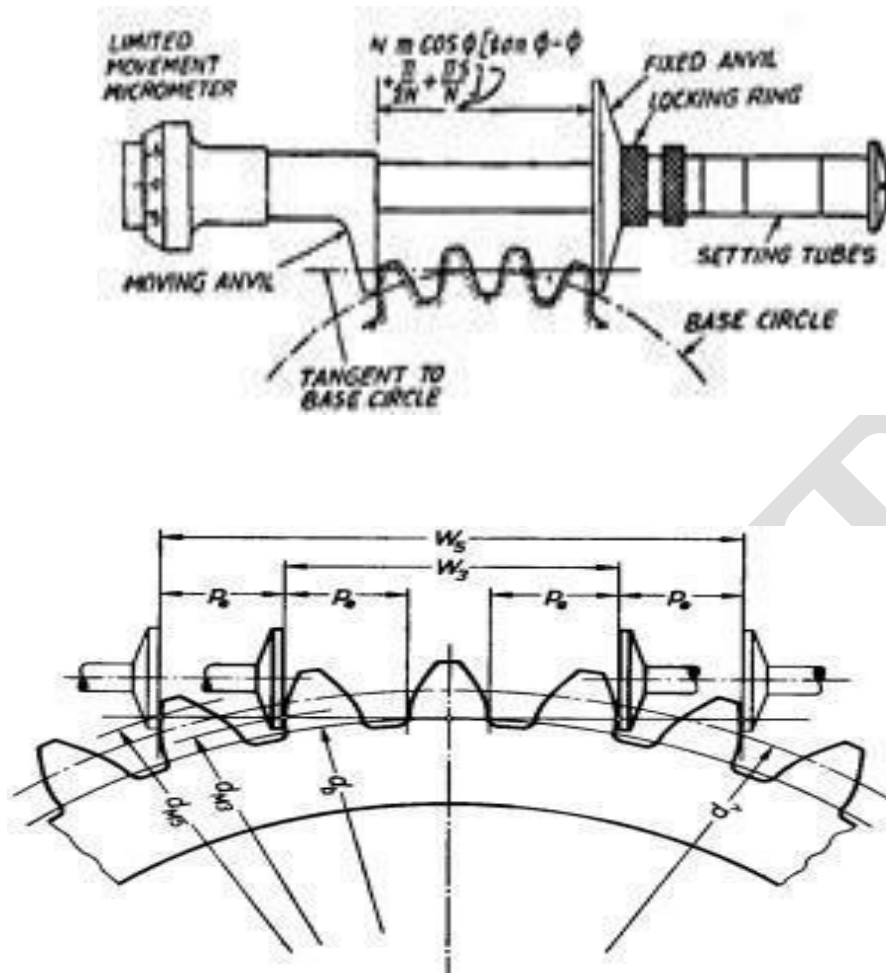

In this method, the span of a convenient number of teeth is measured with the help of the tangent comparator. This uses a single vernier calliper and has, therefore, the following advantages over gear tooth vernier which used two vernier scales

- (i) The measurements do not depend on two vernier readings, each being function of the other.
- (ii) The measurement is not made with an edge of the measuring jaw with the face. Consider a straight generator (edge) ABC being rolled back and forth along a base circle.

Thus the measurements made across these opposed involutes by span gauging will be constant and equal to the arc length of the base circle between the origins of involutes. The value of the distance between two opposed involutes, or the dimension over parallel faces is equal to the distance round the base circle between the points where the corresponding tooth flanks

Constant chord method

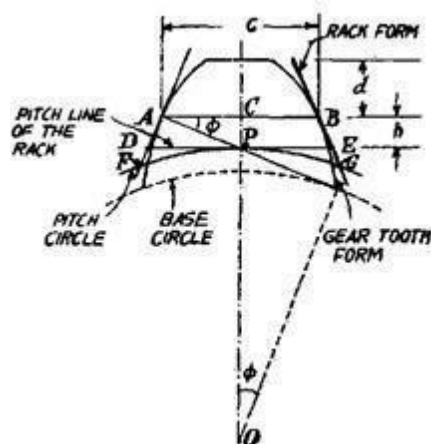

Constant chord of a gear is measured where the tooth flanks touch the flanks of the basic rack. The teeth of the rack are straight and inclined to their centre lines at the pressure angle. Also the pitch line of the rack is tangential to the pitch circle of the gear, the tooth thickness of the rack along this line is equal to the arc tooth thickness of the gear round its pitch circle. Now, since the gear tooth and rack space are in contact in the symmetrical position at the points of contact of the flanks, the chord is constant at this position irrespective of the gear of the system in mesh with the rack.

Part C

6. Explain the following methods to measure the major, minor and effective diameter of a screw thread.

Measurement of various elements of Thread

To find out the accuracy of a screw thread it will be necessary to measure the following:

1. Major diameter.
2. Minor diameter.
3. Effective or Pitch diameter.
4. Pitch
5. Thread angle and form

Measurement of major diameter:

- The instruments which are used to find the major diameter are by
- Ordinary micrometer
 - Bench micrometer.

Ordinary micrometer

The ordinary micrometer is quite suitable for measuring the external major diameter. It is first adjusted for appropriate cylindrical size (S) having the same diameter (approximately). This process is known as 'gauge setting'. After taking this reading 'R' the micrometer is set on the major diameter of the thread, and the new reading is 'R2'.

Bench micrometer

For getting the greater accuracy the bench micrometer is used for measuring the major diameter. In this process the variation in measuring pressure, pitch errors are being neglected. The fiducial indicator is used to ensure all the measurements are made at same pressure. The instrument has a micrometer head with a vernier scale to read the accuracy of 0.002 mm. Calibrated setting cylinder having the same diameter as the major diameter of the thread to be measured is used as setting standard. After setting the standard, the setting cylinder is held between the anvils and the

reading is taken.

Bench Micrometer

∴ The major diameter of screw thread

$$= S \pm (D_2 - D_1)$$

Where, S = Diameter of the setting cylinder.

R_2 = Micrometer Reading on screw thread

R_1 = Micrometer reading on setting cylinder.

Measurement of the major diameter of an Internal thread

The Inter thread major diameter is usually measured by thread comparator fitted with ball – ended styli. First the Instrument is set for a cylindrical reference having the same diameter of major diameter of internal thread and the reading is taken. Then the floating head is retracted to engage the tips of the styli at the root of spring under pressure. For that the new reading is taken,

Measurement of Minor diameter

The minor diameter is measured by a comparative method by using floating carriage diameter measuring machine and small V pieces which make contact with the root of the thread. These V pieces are made in several sizes, having suitable radii at the edges. V pieces are made of hardened steel. The floating carriage diameter-measuring machine is a bench micrometer mounted on a carriage.

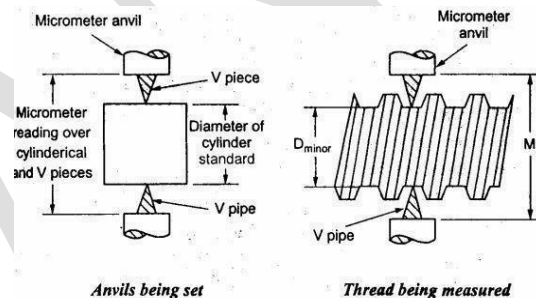

Measurement of Minor diameter

Measurement process

The threaded work piece is mounted between the centers of the instrument and the V pieces are placed on each side of the work piece and then the reading is noted. After taking this reading the work piece is then replaced by a standard reference cylindrical setting gauge.

$$\text{The minor diameter of the thread} = D \pm (R_2 - R_1)$$

Where, D = Diameter of cylindrical gauge

R_2 = Micrometer reading on threaded work piece.

R_1 = Micrometer reading on cylindrical gauge.

Measurement of Minor diameter of Internal threads

The Minor diameter of Internal threads are measured by

- Using taper parallels
- Using Rollers.

Using taper parallels

For diameters less than 200 mm the use of Taper parallels and micro meter is very common. The taper parallels are pairs of wedges having reduced and parallel outer edges. The diameter across their outer edges can be changed by sliding them over each other

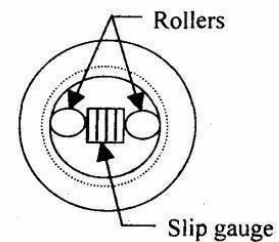
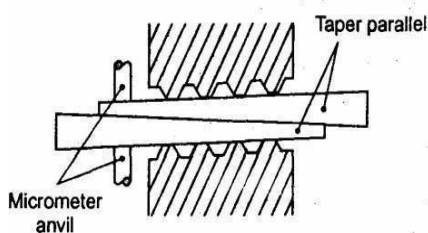

Using rollers

For more than 20mm diameter this method is used. Precision rollers are inserted inside the thread and proper slip gauge is inserted between the rollers. The minor diameter is then the length of slip gauges plus twice the diameter of roller.

Measurement of effective diameter

Effective diameter measurement is carried out by following methods.

1. One wire,
2. Two wires, or
3. Three wires method.
4. Micro meter method.

One wire method

The only one wire is used in this method. The wire is placed between two threads at one side and on the other side the anvil of the measuring micrometer contacts the crests. First the micrometer reading d_1 is noted on a standard gauge whose dimension is approximately same to be obtained by this method.

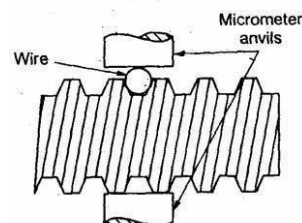

Two wire method

Two-wire method of measuring the effective diameter of a screw thread is given below. In this method wires of suitable size are placed between the standard and the micrometer anvils. First the micrometer reading is taken and let it be R . Then the standard is replaced by the screw thread to be measured and the new reading

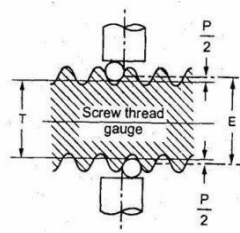

7. Explain the various methods by which roundness is measured. (NOV/DEC 2014, 2016)

Roundness is defined as a condition of a surface of revolution. Where all points of the surface intersected by any plane perpendicular to a common axis in case of cylinder and cone.

Devices used for measurement of roundness

- 1) Diametral gauge.
- 2) Circumferential conferring gauge
- 3) Rotating on center
- 4) V-Block
- 5) Three-point probe.
- 6) Accurate spindle.

Diametral method

The measuring plungers are located 180° apart and the diameter is measured at several places. This method is suitable only when the specimen is elliptical or has an even number of lobes. Diametral check does not necessarily disclose effective size or roundness. This method is unreliable in determining roundness.

Circumferential confining gauge

Fig. shows the principle of this method. It is useful for inspection of roundness in production. This method requires highly accurate master for each size part to be measured. The clearance between part and gauge is critical to reliability. This technique does not allow for the measurement of other related geometric characteristics, such as concentricity, flatness of shoulders etc.

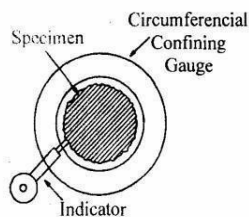

Confining Gauge

Rotating on centers

The shaft is inspected for roundness while mounted on center. In this case, reliability is dependent on many factors like angle of centers, alignment of centres, roundness and surface condition of the centres and centre holes and run out of piece. Out of straightness of the part will cause a doubling run out effect and appear to be roundness error.

V-Block

The set up employed for assessing the circularity error by using V Block is shown in fig. The V block is placed on surface plate and the work to be checked is placed up on it. A diameter indicator is fixed in a stand and its feeler made to rest against the surface of the work.

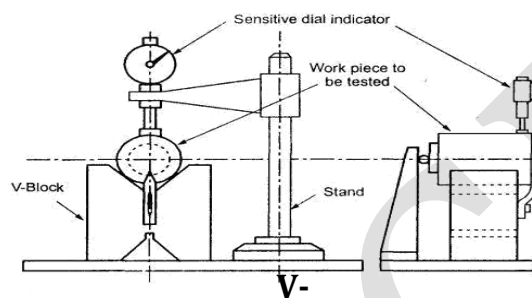

The work is rotated to measure the rise on fall of the work piece. For determining the number of lobes on the work piece, the work piece is first tested in a 60° V-Block and then in a 90° V-Block. The number of lobes is then equal to the number of times the indicator pointer deflects through 360° rotation of the work piece.

Limitations

- The circularity error is greatly affected by the following factors.
- If the circularity error is small, then it is possible that the indicator shows no variation.
- Position of the instrument i.e. whether measured from top or bottom.
- Number of lobes on the rotating part.
- The instrument position should be in the same vertical plane as the point of contact of the part with the V-block.
- A leaf spring should always be kept below the indicator plunger and the surface of the part.

Three point probe

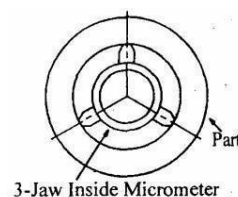

The fig. shows three probes with 120° spacing is very useful for determining effective size they perform like a 60° V-block. 60° V-block will show no error for 5 and 7 lobes magnify the error for 3-lobed parts show partial error for randomly spaced lobes.

UNIT 5

MEASUREMENT OF POWER, FLOW AND TEMPERATURE

PART A

1. Why are measuring instruments calibrated? [Nov/Dec 2015]

Calibration is a comparison between a known measurement (the standard) and the measurement using your instrument. Typically, the accuracy of the standard should be ten times the accuracy of the measuring device being tested. The accuracy of all measuring devices degrade over time. This is typically caused by normal wear and tear. However, changes in accuracy can also be caused by electric or mechanical shock or a hazardous manufacturing environment (e.x., oils, metal chips etc.). Depending on the type of the instrument and the environment in which it is being used, it may degrade very quickly or over a long period of time. The bottom line is that, calibration improves the accuracy of the measuring device. Accurate measuring devices improve product quality.

2. What is the working principle behind strain gauges? [Nov/Dec 2015]

Each metal has its specific resistance. An external tensile force/(compressive force) increases/decreases the resistance by elongating/contracting it. Suppose the original resistance is R and a strain initiated change in resistance is ΔR . Then, the following relation is concluded:

$$\frac{\Delta R}{R} = K_s \cdot \frac{\Delta L}{L} = K_s \cdot \epsilon$$

where, K_s is a gauge factor, the coefficient expressing strain gauge sensitivity. General purpose strain gauges use copper-nickel or nickel-chrome alloy for the resistive element, and the gauge factor provided by these alloys are approximately 2.

3. What are load cells? [May/June 2016]

A load cell is a transducer that is used to create an electrical signal whose magnitude is directly proportional to the force being measured. The various types of load cells include hydraulic load cells, pneumatic load cells and strain gauge load cells. Strain gauge load cells are the most common in industry. These load cells are particularly stiff, have very good resonance values, and tend to have long life cycles in application. Strain gauge load cells work on the principle that the strain gauge (a planar resistor) deforms/stretches/contracts when the material of the load cells deforms appropriately. These values are extremely small and are relational to the stress and/or strain that the material load cell is undergoing at the time. The change in resistance of the strain gauge provides an electrical value change that is calibrated to the load placed on the load cell.

4. Mention the principle involved in bimetallic strip. [May/June 2016]

Bimetallic strip thermometers are mechanical thermometers. They are widely used in

industry for temperature control because of their robustness, temperature range and simplicity. It consists of two strips made of dissimilar metals and bonded together with one end fixed and the other free.

A bimetallic strip is used to convert a temperature change into mechanical displacement. The strip consists of two strips of different metals which expand at different rates as they are heated, usually steel and copper, or in some cases steel and brass. The strips are joined together throughout their length by riveting, brazing or welding. The different expansions force the flat strip to bend one way if heated, and in the opposite direction if cooled below its initial temperature. The metal with the higher coefficient of thermal expansion is on the outer side of the curve when the strip is heated and on the inner side when cooled.

5. What is the working principle of thermocouple?

The basic principle is “when two dissimilar metals are joined together an emf will exist between the two points A and B which is primarily a function of the junction temperature. The above said to be principle is Seeback effect.

6. Define the principles of electrical resistance thermistor. [Apr/ May 2013]

The basic principle involved in thermistor is when it is subjected to a temperature change, the resistance of the thermistor changes. This change in resistance will be the increase in temperature.

7. List any two methods employed for measuring torque. [Nov/Dec 2012]

- i) Torque reaction methods
- ii) Proney brake
- iii) Torque measurement using strain gauges
- iv) Torque measurement using torsion bars

8. Differentiate between primary and secondary transducers. [Apr/May 2012]

S.No	Primary transducer	Secondary transducer
1.	It is a mechanical device	It is an electrical device
2.	It converts a physical signal into mechanical signal	It converts analog output into electrical signal
3.	Ex. Thermister and thermocouples.	Ex. Accelerometer and Piezoelectric transducer.

9. Give the principle of hot wire anemometer. [Apr/ May 2014]

An anemometer is a device for measuring mean and fluctuating velocities in fluid flows. The reduction of temperature of a surface resulting from the heat transferred owing to the fluid flow is related to flow rate.

10. Give the classification of temperature measuring instruments. [Apr/May 2012]

- i) Gas filled temperature measurement
- ii) Electrical resistance temperature measurement
- iii) Thermocouple temperature measurement
- iv) Semiconductor based temperature measurement

11. Give the principle of hot wire anemometer.(Nov Dec 2016)

Hot wire anemometers use a very fine wire electrically heated to some temperature above the ambient. Air flowing past the wire cools the wire. As the electrical resistance of most metals is dependent upon the temperature of the metal, a relationship can be obtained between the resistance of the wire and the flow speed.

12. Name the materials used for thermocouples.(Nov Dec 2016)

- Nickel-alloy
- Platinum/rhodium-alloy
- Tungsten/rhenium-alloy
- Chromel–gold/iron-alloy

13. What is meant by reliability of a measuring instrument?(April may 2017)

Instrument reliability is a way of ensuring that any instrument used for measuring experimental variables gives the same results every time.

14. Write the working principle of pyrometer.(April may 2017)

A pyrometer is a type of remote-sensing thermometer used to measure the temperature of a surface. The main working principle of this type of instruments is that, it senses the heat radiation from a targeted hot body and reads and records its temperature, depending upon the intensity of radiation.

PART B

1. With a neat diagram explain the working of bimetallic strip. [Nov/Dec 2015]

A bimetallic strip is used to convert a temperature change into mechanical displacement. The strip consists of two strips of different metals which expand at different rates as they are heated, usually steel and copper, or in some cases steel and brass.

The strips are joined together throughout their length by riveting, brazing or welding. The different expansions force the flat strip to bend one way if heated, and in the opposite direction if cooled below its initial temperature. The metal with the higher coefficient of thermal expansion is on the outer side of the curve when the strip is heated and on the inner side when cooled

The sideways displacement of the strip is much larger than the small lengthways expansion in either of the two metals. This effect is used in a range of mechanical and electrical devices. In some applications the bimetal strip is used in the flat form. In others, it is wrapped into a coil for compactness. The greater length of the coiled version gives improved sensitivity.

Bimetal strips are used in miniature circuit breakers to protect circuits from excess

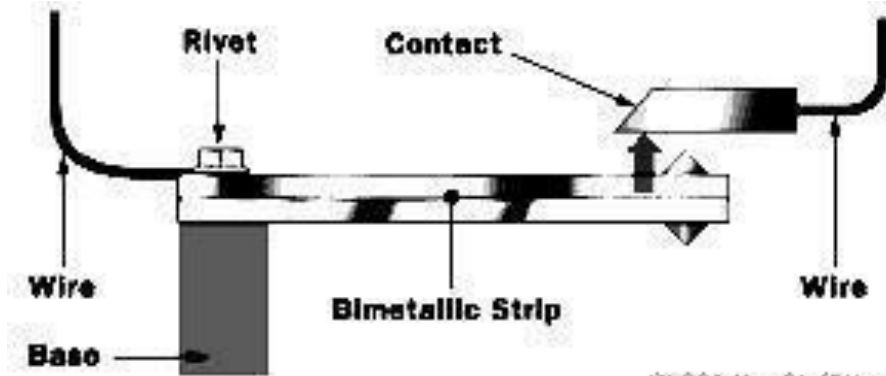

current. A coil of wire is used to heat a bimetal strip, which bends and operates a linkage that unlatches a spring-operated contact. This interrupts the circuit and can be reset when the bimetal strip has cooled down.

Working:

Two pieces of metal with different coefficients of thermal expansion are bonded together to form the bimetallic strip. It is in the form of cantilever beam. When the strip is subjected to a temperature higher than the bonding temperature, it will be bent in one direction. Suppose, if it is subjected to a temperature lower than the bonding temperature, it will be bent in the other direction.

Bimetal strips are also used in time-delay relays, lamp flashers, and fluorescent lamp starters. In some devices the current running directly through the bimetal strip is sufficient to heat it and operate contacts directly.

2. With a neat diagram explain the working of rotometer. [Nov/Dec 2015,2016]

A rotameter is a device that measures the flow rate of fluid in a closed tube. It belongs to a class of meters called variable area meters, which measure flow rate by allowing the cross-sectional area the fluid travels through, to vary, causing a measurable effect.

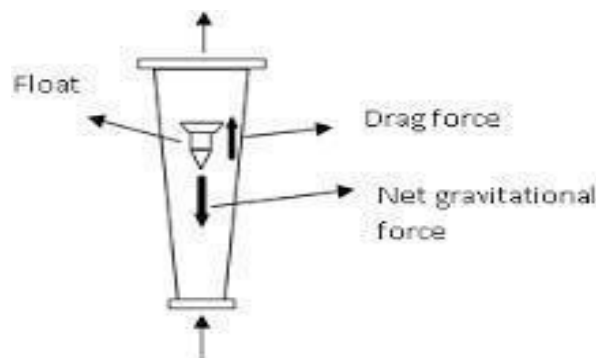

A rotameter consists of a tapered tube, typically made of glass with a 'float', made either of anodized aluminum or a ceramic, actually a shaped weight, inside that is pushed up by the drag force of the flow and pulled down by gravity. The drag force for a given fluid and float cross section is a function of flow speed squared only, see drag equation.

A higher volumetric flow rate through a given area increases flow speed and drag force, so the float will be pushed upwards. However, as the inside of the rotameter is cone shaped, the area around the float through which the medium flows increases, the flow speed and drag force decrease until there is mechanical equilibrium with the float's weight.

Floats are made in many different shapes, with spheres and ellipsoids being the most common. The float may be diagonally grooved and partially colored so that it rotates axially as the fluid passes. This shows if the float is stuck since it will only rotate if it is free. Readings are usually taken at the top of the widest part of the float; the center for an ellipsoid, or the top for a cylinder. Some manufacturers use a different standard.

The "float" must not float in the fluid: it has to have a higher density than the fluid, otherwise it will float to the top even if there is no flow.

The mechanical nature of the measuring principle provides a flow measurement device that does not require any electrical power. If the tube is made of metal, the float position is transferred to an external indicator via a magnetic coupling. This capability has considerably expanded the range of applications for the variable area flowmeter, since the measurement can be observed remotely from the process or used for automatic control.

Advantages:

1. A rotameter requires no external power or fuel, it uses only the inherent properties of the fluid, along with gravity, to measure flow rate.
2. A rotameter is also a relatively simple device that can be mass manufactured out of cheap materials, allowing for its widespread use.
3. Since the area of the flow passage increases as the float moves up the tube, the scale is approximately linear.
4. Clear glass is used which is highly resistant to thermal shock and chemical action.

3. Explain the working of orifice meter with neat sketch. [May/June 2016]

An orifice plate is a device used for measuring flow rate, for reducing pressure or for restricting flow. Either a volumetric or mass flow rate may be determined, depending on the calculation associated with the orifice plate. It uses the same principle as a Venturi nozzle, namely Bernoulli's principle which states that there is a relationship between the pressure of the fluid and the velocity of the fluid. When the velocity increases, the pressure decreases and vice versa.

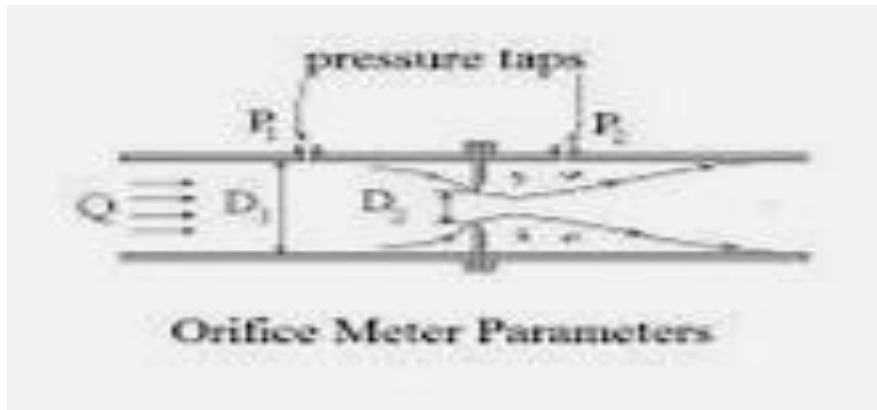

Orifice plates are most commonly used to measure flow rates in pipes, when the fluid is single-phase and well-mixed, the flow is continuous rather than pulsating, the fluid occupies the entire pipe, the flow profile is even and well-developed and the fluid and flow rate meet certain other conditions. Under these circumstances and when the orifice plate is constructed and installed according to appropriate standards, the flow rate can easily be determined using published formulae based on substantial research and published in industry, national and international standards.

Plates are commonly made with sharp-edged circular orifices and installed concentric with the pipe and with pressure tapings at one of three standard pairs of distances upstream and downstream of the plate; these types are covered by ISO 5167 and other major standards. There are many other possibilities. The edges may be rounded or conical; the plate may have an orifice the same size as the pipe except for a segment at top or bottom which is obstructed, the orifice may be installed eccentric to the pipe, and the pressure tapings may be at other positions. Variations on these possibilities are covered in various standards and handbooks. Each combination gives rise to different coefficients of discharge which can be predicted so long as various conditions are met, conditions which differ from one type to another.

Once the orifice plate is designed and installed, the flow rate can often be indicated with an acceptably low uncertainty simply by taking the square root of the differential pressure across the orifice's pressure tapings and applying an appropriate constant.

Even compressible flows of gases that vary in pressure and temperature may be measured with acceptable uncertainty by merely taking the square roots of the absolute pressure and/or temperature, depending on the purpose of the measurement and the costs of ancillary instrumentation. Orifice plates are also used to reduce pressure or restrict flow, in which case they are often called restriction plates.

4. Explain the working of venturimeter with neat sketch. [May/june 2016]

A venturimeter is a device used for measuring the rate of a flow of a fluid flowing

through a pipe.

It consists of three parts.

1. A short converging part 2. Throat 3. Diverging part

It is based on the principle of Bernoulli's equation. Inside of the venturimeter pressure difference is created by reducing the cross-sectional area of the flow passage. The pressure difference is measured by using a differential U-tube manometer. This pressure difference helps in the determination of rate of flow of fluid or discharge through the pipe line. As the inlet area of the venturi is large than at the throat, the velocity at the throat increases resulting in decrease of pressure. By this, a pressure difference is created between the inlet and the throat of the venturi.

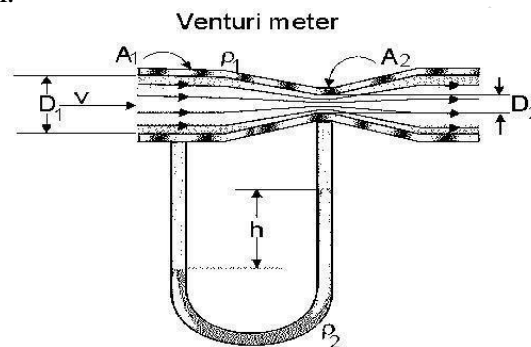

Let

D_1 and D_2 — Diameter at inlet and throat respectively
 P_1 and P_2 — Pressure at inlet and throat
 V_1 and V_2 — Velocity at inlet and throat

The inlet cone or convergent cone tapers towards right from pipe area to throat. So the diameter at inlet is bigger when compared to outlet diameter of the convergent cone. Therefore, the flow rate increases slowly from inlet to exit. But the flow is constant throughout the throat section due to uniform diameter of throat. In the divergent cone, the diameter increases from entry to exit. So the flow decreases at the end.

It is similar to an orifice meter. It has three distinct parts namely convergent cone, throat and divergent cone. A manometer measures the pressure difference between two sections.

Advantages:

1. Loss of head is small and hence, high C_d value and it may approach unity under favorable condition.
2. It has no wear and tear
3. It is less likelihood of becoming clogged with sediment
4. It is more suitable for large flow of water, process fluids, waste gases and suspended solids.

5. Explain the working of Electrical resistance thermometer (NOV/DEC 2016)

Resistance thermometers, also called resistive temperature devices (RTDs), are sensors used to measure temperature by correlating the resistance of the RTD element with temperature. Most RTD elements consist of a length of fine coiled wire wrapped around a ceramic or glass core. The element is usually quite fragile, so it is often placed inside a sheathed probe to protect it. The RTD element is made from a pure material, typically platinum, nickel or copper. The material has a predictable change in resistance as the temperature changes and it is this predictable change that is used to determine temperature.

They are slowly replacing the use of thermocouples in many industrial applications below 600 °C, due to higher accuracy and repeatability

There are five main categories of RTD sensors: thin film, wire-wound, and coiled elements. While these types are the ones most widely used in industry there are some places where other more exotic shapes are used, for example carbon resistors are used at ultra low temperatures (-173 °C to -273 °C).

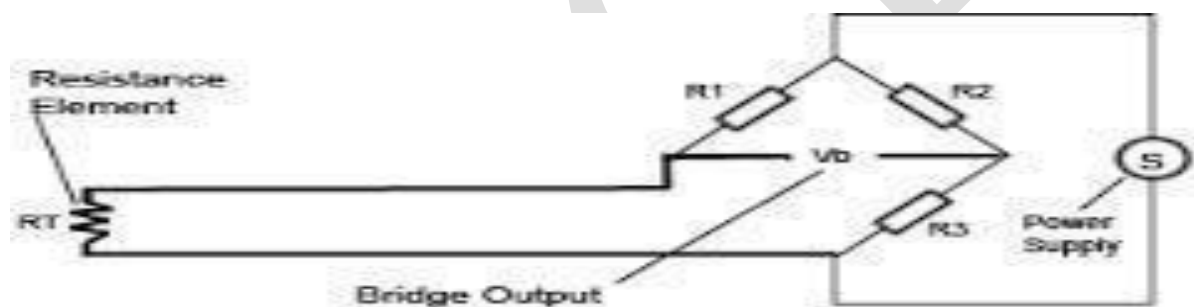

- Carbon resistor elements are widely available and are very inexpensive. They have very reproducible results at low temperatures. They are the most reliable form at extremely low temperatures. They generally do not suffer from significant hysteresis or strain gauge effects.
- Strain free elements use a wire coil minimally supported within a sealed housing filled with an inert gas. These sensors are used up to 961.78 °C and are used in the SPRT's that define ITS-90. They consist of platinum wire loosely coiled over a support structure so the element is free to expand and contract with temperature. They are very susceptible to shock and vibration as the loops of platinum can sway back and forth causing deformation.

Thin film PRT

Thin film elements have a sensing element that is formed by depositing a very thin layer of resistive material, normally platinum, on a ceramic substrate. This film is then coated with an epoxy or glass that helps protect the deposited film and also acts as a strain relief for the external

lead- wires. Disadvantages of this type are that they are not as stable as their wire wound or coiled counterparts. They also can only be used over a limited temperature range due to the different expansion rates of the substrate and resistive deposited giving a "strain gauge" effect that can be seen in the resistive temperature coefficient. These elements work with temperatures to 300 °C (572°F) without further packaging but can operate up to 600 °C (1,112 °F) when suitably encapsulated in glass or ceramic. Nowadays there are special high temperature RTD elements which can be used up to 900 °C (1,652 °F) with the right encapsulation.

Wire Wound PRT

Wire-wound elements can have greater accuracy, especially for wide temperature ranges. The coil diameter provides a compromise between mechanical stability and allowing expansion of the wire to minimize strain and consequential drift. The sensing wire is wrapped around an insulating mandrel or core. The winding core can be round or flat, but must be an electrical insulator. The coefficient of thermal expansion of the winding core material is matched to the sensing wire to minimize any mechanical strain. This strain on the element wire will result in a thermal measurement error. The sensing wire is connected to a larger wire, usually referred to as the element lead or wire. This wire is selected to be compatible with the sensing wire so that the combination does not generate an emf that would distort the thermal measurement. These elements work with temperatures to 660 °C.

Coil Element PRT

Coiled elements have largely replaced wire-wound elements in industry. This design has a wire coil which can expand freely over temperature, held in place by some mechanical support which lets the coil keep its shape. This "strain free" design allows the sensing wire to expand and contract free of influence from other materials; in this respect it is similar to the SPRT, the primary standard upon which ITS-90 is based, while providing the durability necessary for industrial use. The basis of the sensing element is a small coil of platinum sensing wire. This coil resembles a filament in an incandescent light bulb. The housing or mandrel is a hard fired ceramic oxide tube with equally spaced bores that run transverse to the axes. The coil is inserted in the bores of the mandrel and then packed with a very finely ground ceramic powder. This permits the sensing wire to move while still remaining in good thermal contact with the process. These elements work with temperatures to 850 °C.

PART C

1. With a neat diagram explain the working of Thermocouple. [Nov/Dec 2015]

Thermocouple is an electrical device consisting of two different conductors forming electrical junctions at differing temperatures. A thermocouple produces a temperature-dependent voltage as a result of the thermoelectric effect, and this voltage can be interpreted to measure temperature. Thermocouples are a widely used type of temperature sensor.

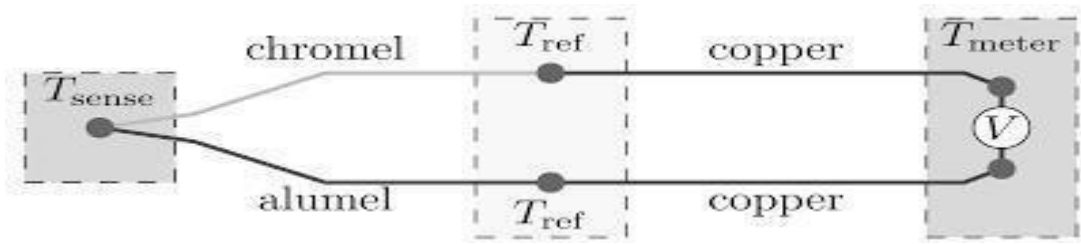

Commercial thermocouples are inexpensive, interchangeable, are supplied with standard connectors, and can measure a wide range of temperatures. In contrast to most other methods of temperature measurement, thermocouples are self powered and require no external form of excitation. The main limitation with thermocouples is accuracy; system errors of less than one degree Celsius ($^{\circ}\text{C}$) can be difficult to achieve. Thermocouples are widely used in science and industry; applications include temperature measurement for kilns, gas turbine exhaust, diesel engines, and other industrial processes. Thermocouples are also used in homes, offices and businesses as the temperature sensors in thermostats, and also as flame sensors in safety devices for gas-powered major appliances.

Thermocouple Insulation:

The wires that make up the thermocouple must be insulated from each other everywhere, except at the sensing junction. Any additional electrical contact between the wires, or contact of a wire to other conductive objects, can modify the voltage and give a false reading of temperature.

Plastics are suitable insulators for low temperatures parts of a thermocouple, whereas ceramic insulation can be used up to around $1000\text{ }^{\circ}\text{C}$. Other concerns (abrasion and chemical resistance) also affect the suitability of materials.

When wire insulation disintegrates, it can result in an unintended electrical contact at a different location from the desired sensing point. If such a damaged thermocouple is used in the closed loop control of a thermostat or other temperature controller, this can lead to a runaway overheating event and possibly severe damage, as the false temperature reading will typically be lower than the sensing junction temperature. Failed insulation will also typically outgas, which can lead to process contamination. For parts of thermocouples used at very high temperatures or in contamination-sensitive applications, the only suitable insulation may be vacuum or inert gas; the mechanical rigidity of the thermocouple wires is used to keep them separated.

Thermocouples are suitable for measuring over a large temperature range, from -270 up to $3000\text{ }^{\circ}\text{C}$. Applications include temperature measurement for kilns, gas turbine exhaust, diesel engines, other industrial processes and fog machines. They are less suitable for applications where smaller temperature differences need to be measured with high accuracy, for example the range $0-100\text{ }^{\circ}\text{C}$ with $0.1\text{ }^{\circ}\text{C}$ accuracy. For such applications thermistor, silicon band gap temperature sensors and resistance thermometers are more suitable.

2. With a neat diagram explain the working of Optical pyrometer. [Nov/Dec2015]

Principle:

This method refers the identification of the temperature of a surface with the colour of the radiation emitted. The optical pyrometer compares the brightness of the image produced by the temperature source with the reference temperature lamp.

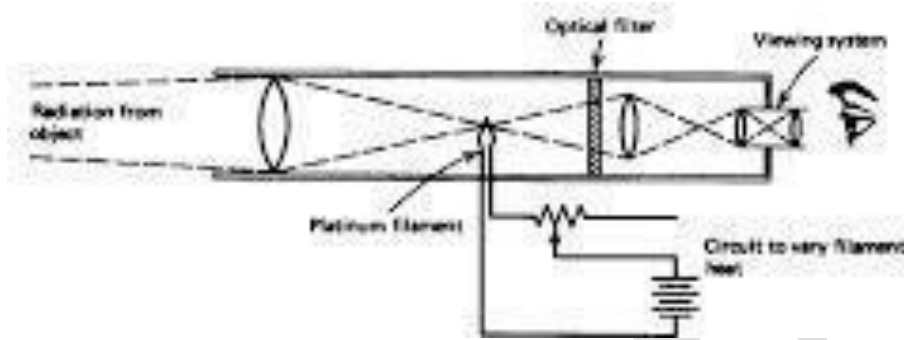

Construction:

The optical pyrometer has an eyepiece at one end and an objective lens on the other end. In between objective lens and standard lamp, an absorption filter is placed and it is used to increase the range of temperature.

A red filter is placed between eyepiece and standard lamp which allows only a narrow band of wavelength. A battery, ammeter and rheostat are connected to a standard lamp.

Working:

A source temperature to be measured is focused onto the standard lamp using objective lens. An absorption filter at the front of the device reduces the intensity of the incoming radiation so that the standard lamp may be operated at low level.

Now, the colour of the filament is matched with the colour of the incoming radiation by an adjustment of the lamp current. It means, the standard lamp is placed in the optical path of the incoming radiation.

The appearance of the lamp filament is shown. There are three conditions. First, the filament is cooled below the source temperature. The filament is hotter than temperature source in the second condition. Third condition is filament equal brightness with the source temperature.

The red filter is fixed in the eyepiece to ensure that comparisons are made with monochromatic radiation. Finally, the current flowing through the lamp is measured by using the ammeter and it is the temperature of the source when it is calibrated with temperature equivalent.

Application:

1. It is used to measure the furnace temperature.
2. It is widely used in two radiation temperature methods for hightemperatures.

Advantages:

1. It is relatively expensive
2. It does not depend on the surface properties of the material
3. It is a quite accurate method for the measurement of radiant energy from the surface.

Disadvantages:

1. It is not suitable for less temperature measurement
2. Adjustment of standard lamp temperature is done by manually. So it will make some error in the measurement.

3. Discuss the working principle of bourdon tube pressure gauge

Bourdon tube pressure gauges are used for the measurement of relative pressures from 0.6 ... 7,000 bar. They are classified as mechanical pressure measuring instruments, and thus operate without any electrical power.

Bourdon tubes are radially formed tubes with an oval cross-section. The pressure of the measuring medium acts on the inside of the tube and produces a motion in the non-clamped end of the tube. This motion is the measure of the pressure and is indicated via the movement.

The C-shaped Bourdon tubes, formed into an angle of approx. 250°, can be used for pressures up to 60 bar. For higher pressures, Bourdon tubes with several superimposed windings of the same angular diameter (helical tubes) or with a spiral coil in the one plane (spiral tubes) are used.

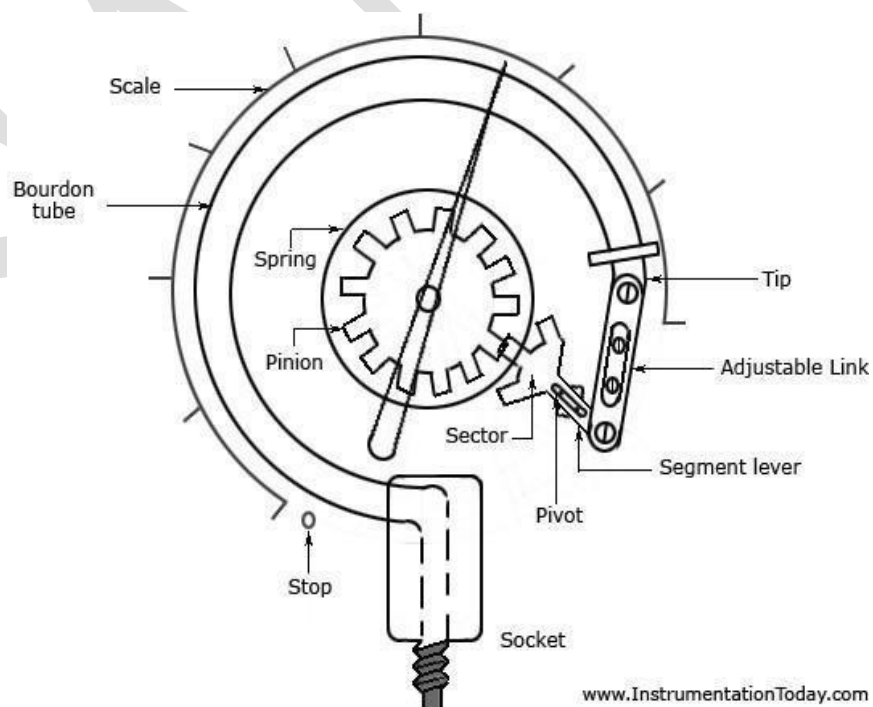

Bourdon Tube Pressure Gauge

As the fluid pressure enters the bourdon tube, it tries to be reformed and because of a free tip available, this action causes the tip to travel in free space and the tube unwinds. The simultaneous actions of bending and tension due to the internal pressure make a non-linear movement of the free tip. This travel is suitably guided and amplified for the measurement of the internal pressure. But the main requirement of the device is that whenever the same pressure is applied, the movement of the tip should be the same and on withdrawal of the pressure the tip should return to the initial point.

A lot of compound stresses originate in the tube as soon as the pressure is applied. This makes the travel of the tip to be non-linear in nature. If the tip travel is considerably small, the stresses can be considered to produce a linear motion that is parallel to the axis of the link. The small linear tip movement is matched with a rotational pointer movement. This is known as multiplication, which can be adjusted by adjusting the length of the lever. For the same amount of tip travel, a shorter lever gives larger rotation. The approximately linear motion of the tip when converted to a circular motion with the link-lever and pinion attachment, a one-to-one correspondence between them may not occur and distortion results. This is known as angularity which can be minimized by adjusting the length of the link.

4. With neat diagram discuss the working of liquid in glass thermometer

Liquid-in-glass thermometers, in particular mercury thermometers, have been around for almost 300 years. Thermometer relies on the expansion of a liquid with temperature. Liquid is contained in a sealed glass bulb and it expands into the fine bore in the thermometer stem.

With a liquid-in-glass thermometer the liquid inside expands when it is heated. Its volume increases and rises up the tube. The liquid expands much more than the glass itself.

ADVANTAGES

23.7.02 Clinical thermometer

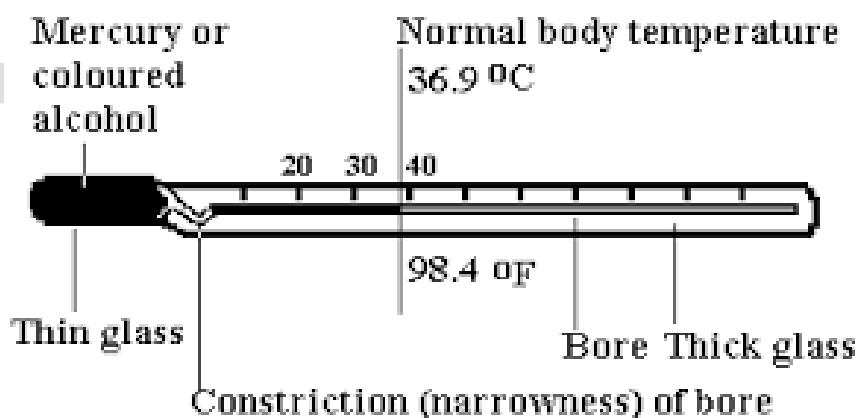

- They are comparatively cheaper than other temperature measurement devices.
- They are handy and convenient to use.
- Unlike electrical thermometers, they do not necessitate power supply or batteries for charging.

- They can be frequently applied in areas where there is problem of electricity.
- They provide very good repeatability and their calibration remains unaffected.
- They are considered inapt for applications involving extremely high or low temperatures.
- They cannot be applied in regions where highly accurate results are desirable.

5. With neat diagram explain the construction and working principle of pitot tube.

Basically, a pitot tube is used in wind tunnel experiments and on airplanes to measure flow speed. It's a slender tube that has two holes on it. The front hole is placed in the airstream to measure what's called the stagnation pressure. The side hole measures the static pressure.

The basic pitot tube consists of a tube pointing directly into the fluid flow. As this tube contains fluid, a pressure can be measured; the moving fluid is brought to rest (stagnates) as there is no outlet to allow flow to continue. This pressure is the stagnation pressure of the fluid, also known as the total pressure or (particularly in aviation) the pitot pressure.

The measured stagnation pressure cannot itself be used to determine the fluid flow velocity (airspeed in aviation). However, Bernoulli's equation states:

$$\text{Stagnation pressure} = \text{static pressure} + \text{dynamic pressure}$$

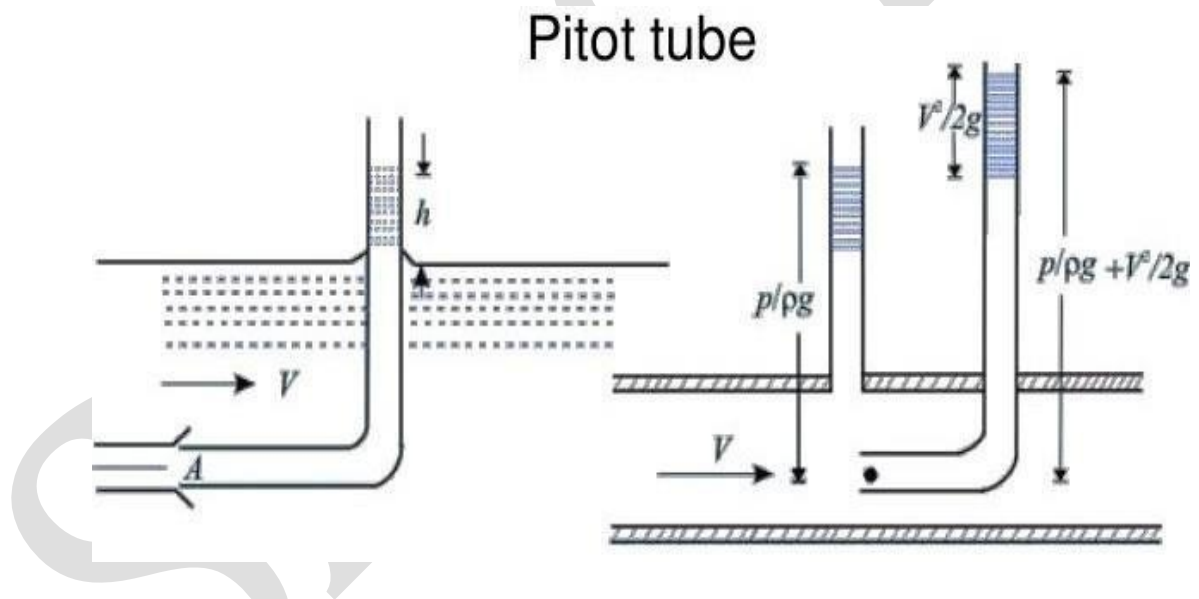

In industry, the flow velocities being measured are often those flowing in ducts and tubing where measurements by an anemometer would be difficult to obtain. In these kinds of measurements, the most practical instrument to use is the pitot tube. The pitot tube can be inserted through a small hole in the duct with the pitot connected to a U-tube water gauge or some other differential pressure gauge for determining the flow velocity inside the ducted wind tunnel.

B.E. / B.Tech. DEGREE EXAMINATION, APRIL/MAY 2017
Fifth Semester
ME6504 –ENGINEERING METROLOGY AND MEASUREMENT
(Regulation 2013)

Time: 3 Hours

Maximum marks: 100

Answer ALL questions

PART - A (10x2=20 marks)

1. Define traceability(Ref P.NO 2)
2. What is difference between gauging and measurement. (Ref P.NO 3)
3. Why is rocking procedure followed when measuring with a dial bore gauge.
(Ref P.NO18)
4. Name any four instrument used measuring internal diameter in components(Ref P.NO18)
5. What is meant by “Qualifying the tip” in CMM(Ref P.NO45)
6. Write any four application of artificial vision system in manufacturing industries(Ref P.NO45)
7. Calculate the “best size wire” for checking the effective diameter of a M10 X 2.5 thread.
8. Is assessment length greater /lesser than traverse length in surface finishmeasurement? why? (Ref P.NO 62)
9. What is meant by reliability of a measuring instruments(Ref P.NO 79)
10. Write the working principle of pyrometer. (Ref P.NO 79)

PART - B (10x2=20 marks)

11. (a) Explain the various error in measurement(Ref P.NO 5)
Or
(b) What is the need of calibration? Explain the classification of various standards(Ref P.NO 4)
12. (a) Explain the construction and working principle of autocollimator with a neat diagram (Ref P.NO37)
Or
(b) Explain the construction, working principle and application of sine bar(Ref P.NO40)
13. (a) Explain the working principle of AC laser laser interferometer and how the

straightness is measured(Ref P.NO47)

Or

(b) With neat diagram explain the working principle of touch trigger probes(Ref P.NO58)

14. (a) With neat diagram explain how gear tooth thickness is measured using a gear tooth Vernier caliper (Ref P.NO67)

Or

(b) Derive the expression for tooth thickness of the gear in the constant chord method (Ref P.NO 67)

15. (a) With neat sketch explain construction and working principle of following (i) Rotameter (Ref P.NO 81) (ii) Resistance thermometer (Ref P.NO 86)

Or

(b) With neat sketch explain construction and working principle of following (i) Pitot tube (Ref P.NO 95) (ii) Bimetallic strip (Ref P.NO 80)

PART - C (10x2=20 marks)

16. (a) Calculate the tolerance, fundamental deviation and limits of sizes for the shaft designated as 40 H8/f7. Standard tolerance for IT 7 is 16i and IT 8 is 25i. Where 'i' is the standard tolerance unit. Upper deviation for 'f' shaft is $-5.5D^{0.41}$, 40mm lies in the diameter range 30 – 50 mm. (Ref P.NO42)

Or

(b) Design general type GO and NOGO gauge for a 40H7/d8 fit. 40mm lies in the diameter range 30 – 50 mm. Show graphically the disposition of gauge tolerance zones relative to the work tolerance zones. Standard tolerance for IT 7 is 16i and IT 8 is 25i. Where 'i' is the standard tolerance unit. The upper deviation for 'd' shaft is $-16D^{0.44}$. (Ref P.NO42)

B.E. / B.Tech. DEGREE EXAMINATION, NOVEMBER/DECEMBER 2016

Fifth Semester

ME6504 –ENGINEERING METROLOGY AND MEASUREMENT

(Regulation 2013)

Time: 3 Hours

Maximum marks: 100

Answer ALL questions

PART - A (10x2=20 marks)

1. Brief on sensitivity in measurement. (Ref P.NO 2)
2. Differentiate between accuracy and precision. (Ref P.NO 2)
3. Write short notes on Bevel protractor. (Ref P.NO18)
4. Write short notes on interchangeability. (Ref P.NO 18)

5. Why laser is used as light source in interferometers? **(Ref P.NO45)**
6. Name the different stages involved in the machine vision based measurement. **(Ref P.NO45)**
7. Define drunken thread. **(Ref P.NO62)**
8. What are the various factors affecting surface roughness of a machined component? **(Ref P.NO62)**
9. Give the principle of hot wire anemometer. **(Ref P.NO 79)**
10. Name the materials used for thermocouples. **(Ref P.NO 79)**

PART - A (10x2=20 marks)

11. (a) With a suitable example explain the various elements of generalized measurement systems. **(Ref P.NO 11)**

Or

(b) Describe the different types of error and its causes. **(Ref P.NO 5)**

12. (a) Discuss in detail about the various types of limit gauges with neat sketch **(Ref P.NO 11)**

Or

(b) (i) Explain the working principle of Angle Dekkor with neat sketch.
(ii) Write its advantages **(Ref P.NO 34)**

13. (a) (i) With neat diagram explain the working of AC laser interferometer
(ii) List the advantages of AC laser interferometer **(Ref P.NO 47)**

Or

(b) (i) With neat sketch briefly explain the different types of CMM based on its contraction

(ii) List out the advantages of CMM **(Ref P.NO 51)**

14. (a) Describe the construction of gear tooth Vernier caliper. Explain how it can be used for measuring tooth thickness **(Ref P.NO 67)**

Or

(b) Enlist and explain the different methods used for measuring the roundness **(Ref P.NO 74)**

15. (a) (i) Explain the working of rotameter in flow measurement **(Ref P.NO 81)**

(ii) Discuss the working principle of Bourdon tube pressure gauge **(Ref P.NO 92)**

Or

(b) (i) Draw the construction of electrical resistance thermometer. Explain how it can be used for temperature measurement **(Ref P.NO 86)**

(ii) With the neat diagram discuss the working of liquid in glass thermometer **(Ref P.NO 93)**

**B.E. / B.Tech. DEGREE EXAMINATION, APRIL/MAY 2016 Fifth Semester
ME6504 –ENGINEERING METROLOGY AND MEASUREMENT**

(Regulation 2013)

Time: 3 Hours

Maximum marks: 100

Answer ALL questions

PART - A (10x2=20 marks)

1. What are the factors affecting the inherent characteristics of measuring instruments?
2. Explain line and end standards.
3. List out any four angular measuring instruments used in metrology **(Ref P.NO 14)**
4. What are the advantages of pneumatic comparator? **(Ref P.NO 14)**
5. What are the different types of geometrical tests conducted on machine tools **(Ref P.NO 37)**
6. Write the advantages of machine vision system.
7. What is best size of wire? **(Ref P.NO 51)**
8. What are factors affecting surface roughness? **(Ref P.NO 51)**
9. What are load cells? **(Ref P.NO 67)**
10. Mention the principle involved in bimetallic strip **(Ref P.NO 68)**

PART - B (16x5=80 marks)

11(a) Explain various causes of errors **(Ref P.NO 4)** **(16)**

(OR)

(b) Elaborate on different methods of measurements **(Ref P.NO 7)**

12a) Explain Johansson microkator and sigma comparator with neat sketches **(16)**

(OR)

(b) Discuss about various types of limit gauges **(Ref P.NO 15)** **(16)13a)**

Explain working of laser interferometer **(Ref P.NO 40)** **(16)**

(OR)

(b) Explain different types of CMM and their constructional features **(16)(Ref P.NO 43)**

14(a) Define various terminologies of screw thread with suitable diagrams (16)

(OR)

(b) Derive the expression for finding the effective diameter by two and three wire method (Ref P.NO 63) (16)

15(a) Discuss about any two types of measurement of temperature (Ref P.NO 70) (16)

(OR)

(b) Explain the working of rotometer and orificemeter with neat sketches (16)(Ref P.NO 71)

Reg No.

--	--	--	--	--	--	--	--	--	--	--	--	--	--	--	--	--	--	--	--

B.E. / B.Tech. DEGREE EXAMINATION, NOVEMBER/DECEMBER 2015 Fifth

Semester

ME6504 –ENGINEERING METROLOGY AND MEASUREMENT

(Regulation 2013)

Time: 3 Hours

Maximum marks: 100

Answer ALL questions

PART - A (10x2=20 marks)

1. What is the difference between repeatability and reproducibility? (Refp.no11)
2. What is the difference between allowance and tolerance?
3. Write any two precautions to be followed when using gauge blocks. (Ref P.NO 15)
4. Why are lasers used in metrology? (Ref P.NO 14)
5. What are touch trigger probes?
6. What are diffraction gratings? (Ref P.NO 38)
7. Define “material ratio” with reference to surface finish measurement.
8. How is roundness measured in the Least squares circle method?
9. Why are measuring instruments calibrated? (Ref P.NO 67)
10. What is the working principle behind strain gauges? (Ref P.NO 67)

PART - B (16x5=80 marks)

11(a) What are the various elements of metrology? With examples, explain how these elements influence the accuracy of measurements? (16)

(OR)

(b) Explain with neat diagrams the method for measurement of straightness of a machine tool guide way using an Autocollimator. (16)
Show the tabulation to determine the error in straightness by choosing a reference line passing through the first and last points of the guide way.

12a) (i) with a neat diagram explain the working of angle dekkor (12)

(Ref P.NO 30)

(4)

(ii) why are sine bars not used for measuring large angles

(Ref P.NO 13)

(OR)

- (b)** Calculate the limits for a hole shaft pair designated 25 H8/d9. **(16)**
Show graphically the disposition of tolerance zones with reference to the zero line. The lower deviation for a H type hole is zero. 25 mm lies in the diameter range 18 mm to 30 mm. standard tolerance for IT 8 is 25 i and IT 9 is 40 i, where “i” is the standard tolerance unit in microns and is given as $i(\mu\text{m})=0.45 + 0.001D$, (D is in mm). the upper deviation for ‘d’ shaft – $16D^{0.44}$
- 13a)** (i) What is a co ordinate Measuring Machine? What are its basic elements? **(Ref P.NO 43)** **(6)**
(ii) Explain the working principle of a DC laser interferometer with a neat diagram? **(Ref P.NO 50)** **(10)**
- (OR)**
- (b)** Write briefly about the various stages involved in machine vision? **(16)**
(Ref P.NO 45)
- 14(a)** (i)What is meant by functional inspection of gears? How it is done? **(2)**
(ii) How is the tooth thickness of a gear measured in the base tangent method? Derive the expression for tooth thickness of a gear in this method? **(10)**
- (OR)**
- (b)** (i)With a neat diagram explain the working principle of any one stylus type surface finish measuring instrument? **(Ref P.NO 56)** **(10)**
(ii) How is surface finish indicated in an engineering drawing? **(6)**
What are the various elements indicated in the symbol?
(Ref P.NO 57)
- 15(a)** With a neat diagram explain the working principle of rotameter and pitot tube? **(Ref P.NO 71)** **(16)**
- (OR)**
- (b)** With a neat diagram explain the working of bimetallic strip and thermocouple? **(Ref P.NO 70 & 78)** **(16)**